

Hand-Powered Water Filter

Detail and Assembly

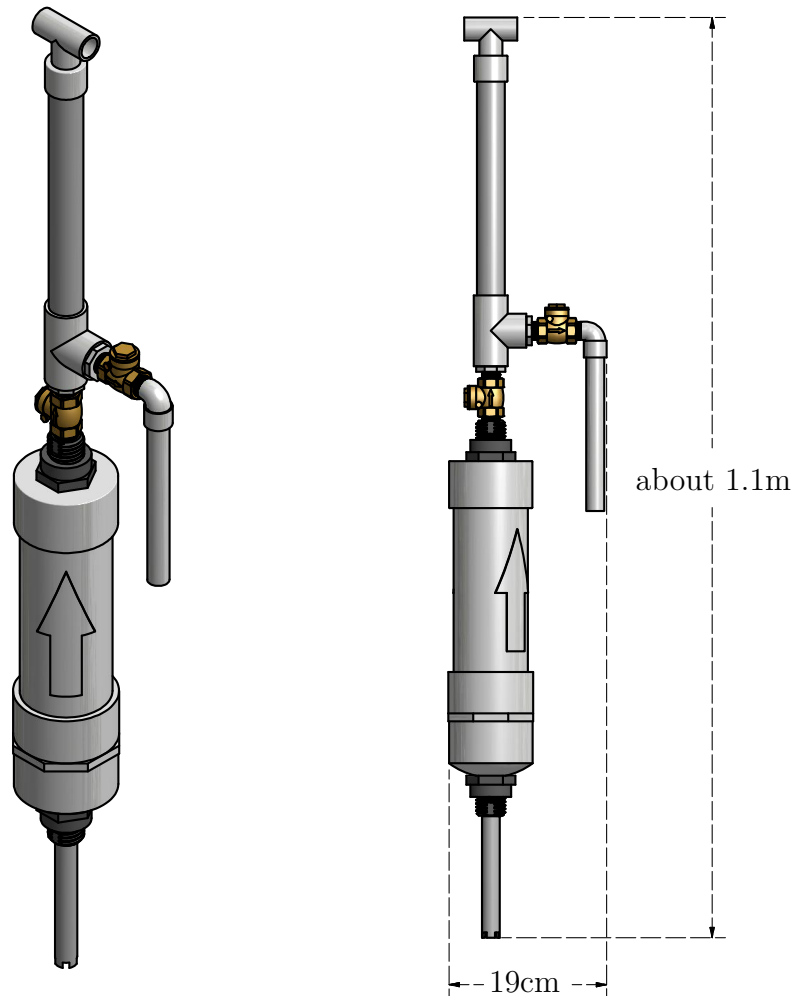

Version 3.01

Patent Pending

Last Updated September 11, 2017

Christopher Bulkley - Logston

Kaylea Brase

Sushant Bamane

Media Specifications (in order of flow)

media	specification	removes
course pre-filter foam	5 – 100 μm nominal pore size	sediment
carbon filter block	0.1 μm absolute pore size	most biological pathogens

Filter Media Interior View

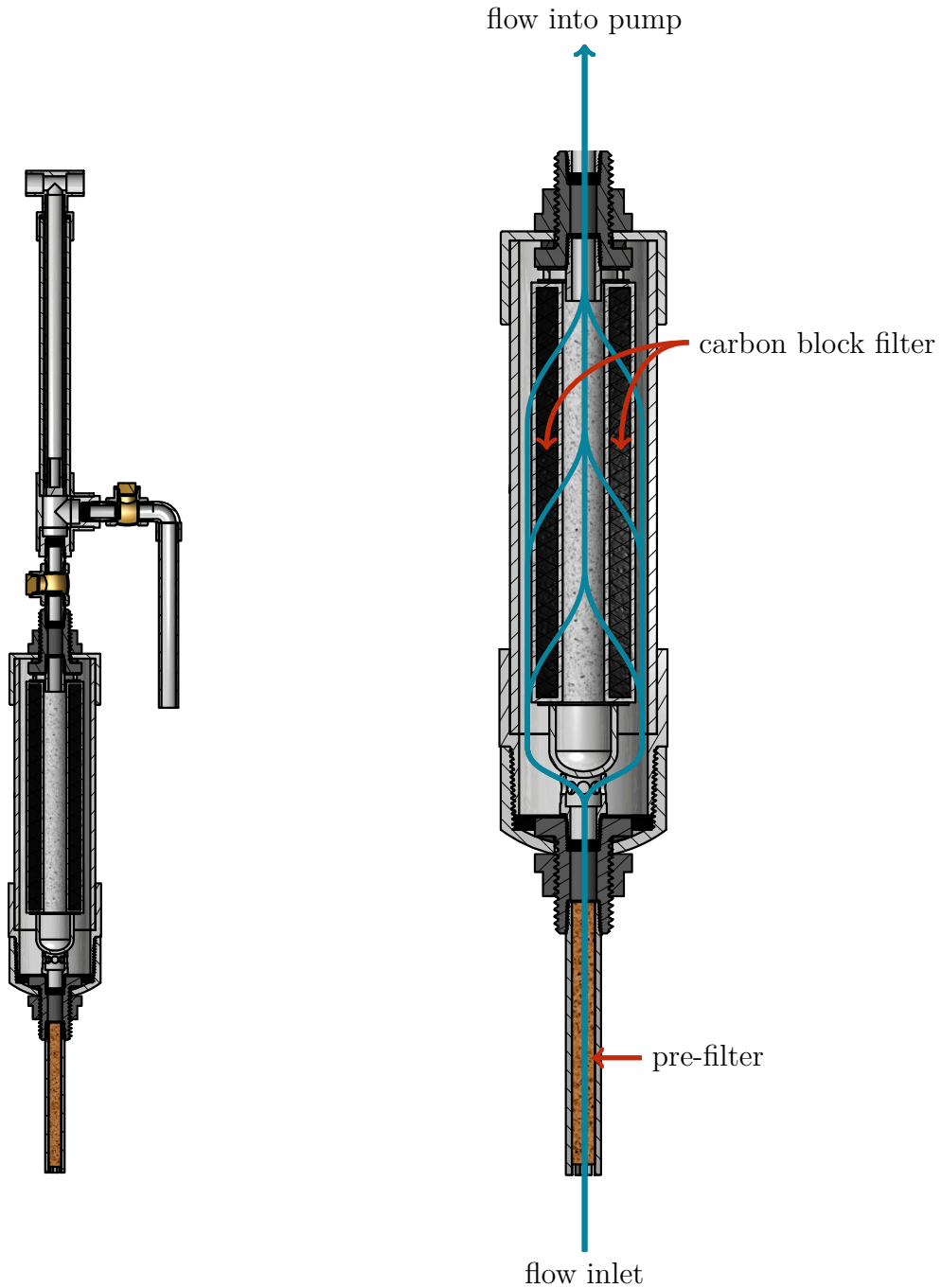

Pump Detail

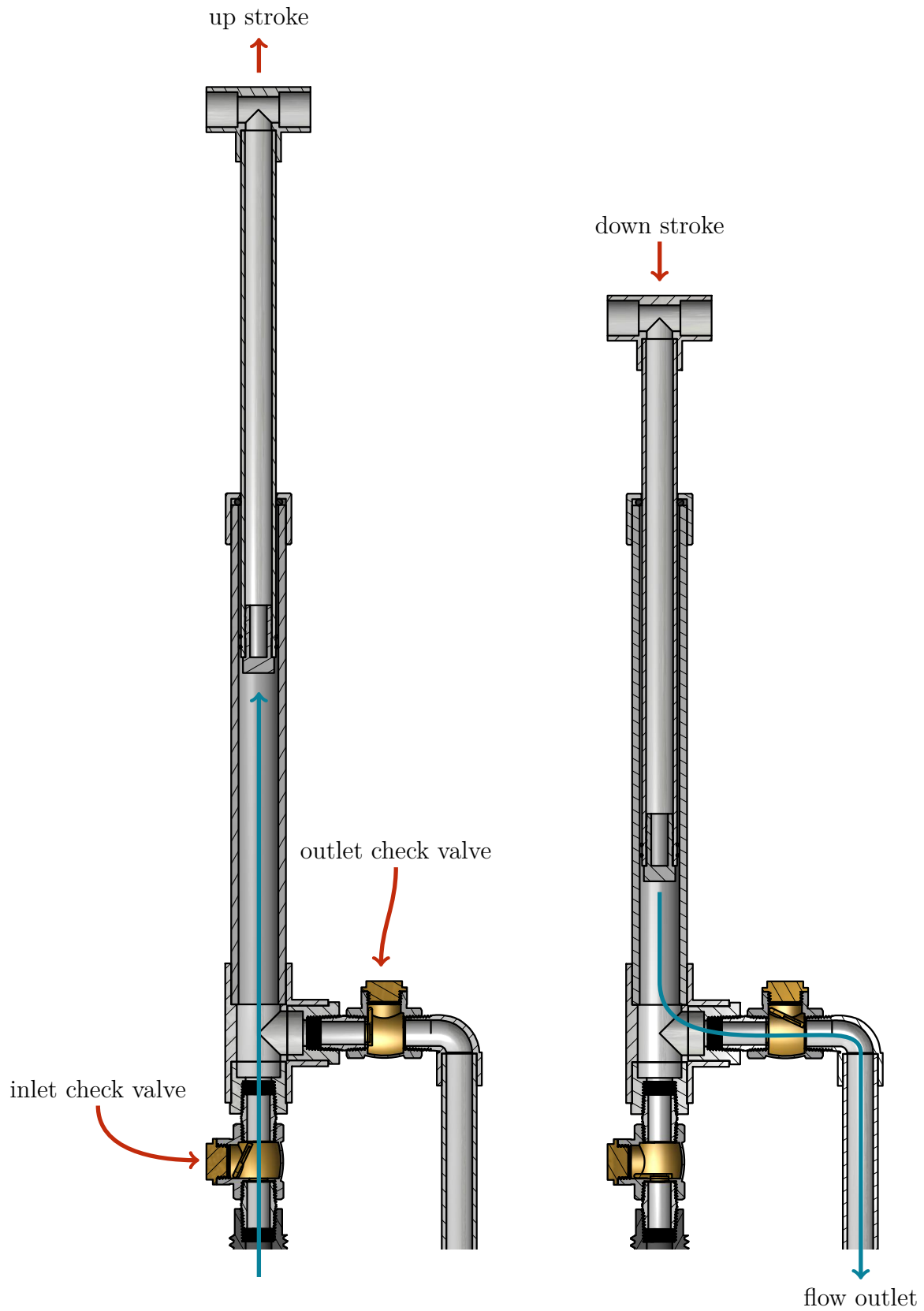

Part List

part no.	description	quantity	ppu	total
01	3" pipe, SCH 40, about 12" long	1	₹20	₹20
02	3" female socket end cap, SCH 40	1	₹30	₹30
03	3" female socket to male thread adapter, SCH 40	1	₹45	₹45
04	1/2" tank connector	2	₹40	₹80
05	1/2", half-threaded nipple, SCH 80	1	₹10	₹10
06	1 1/8" ID, 2 1/8" OD rubber washer	2	₹5	₹10
07	1 1/2" pipe slice, SCH 40, about 1/4" thick	1	₹1	₹1
08	1/2" tank connector gasket	1	₹5	₹5
09	1/2" tank connector nut	2	₹5	₹10
10	carbon block filter	1	₹30	₹30
11	1" fem. socket, 1/2" male thread adptr, SCH 40	1	₹20	₹20
12	3" female thread end cap, SCH 40	1	₹30	₹30
13	1" female socket end cap, SCH 40	1	₹15	₹15
14	1/2", half-threaded nipple, SCH 80, 7" long	1	₹5	₹5
15	11/16" OD, 3/8" ID washer	1	₹2	₹2
16	6" long piece of pre-filter foam	1	₹10	₹10
17	1/2" close nipple, SCH 80	3	₹20	₹60
18	1/2" swing check valve	2	₹200	₹400
19	1" socket tee, SCH 40	1	₹40	₹40
20	1" male socket, 1/2" fem. thread bushing, SCH 40	2	₹20	₹40
21	1" pipe piece, SCH 80, about 12" long	1	₹20	₹20
22	1/2" male thread, female socket elbow, SCH 40	1	₹15	₹15
23	1/2" pipe piece, SCH 40, about 8" long	1	₹10	₹10
24	1/2" pipe piece, SCH 40, about 12" long	1	₹15	₹15
25	plug for 1/2", SCH 40 pipe	1	₹15	₹15
26	O-ring, US 19	1	₹5	₹5
27	O-ring, US 267	1	₹5	₹5
28	1", female socket end cap, SCH 40	1	₹20	₹20
29	1/2" socket tee, SCH 40	1	₹20	₹20
			total	₹988

Step 01: Create arrow mark on side of 3" pipe.

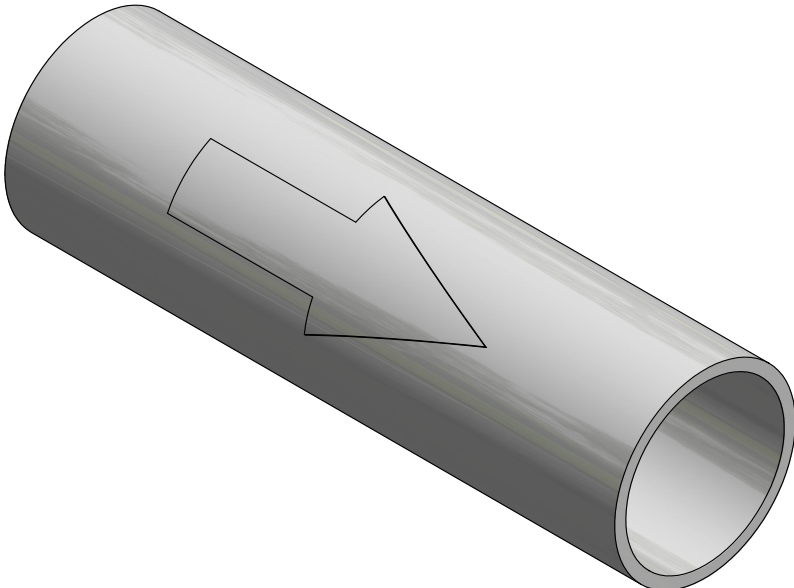
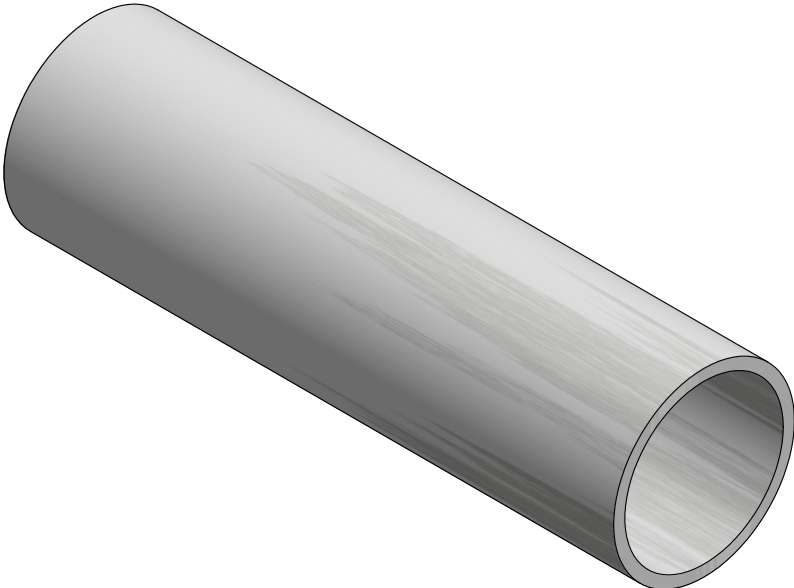

part no.

description

01

3" pipe, SCH 40, about 12" long

Step 02: Drill 1³/₈" hole in top of 3" socket end cap.

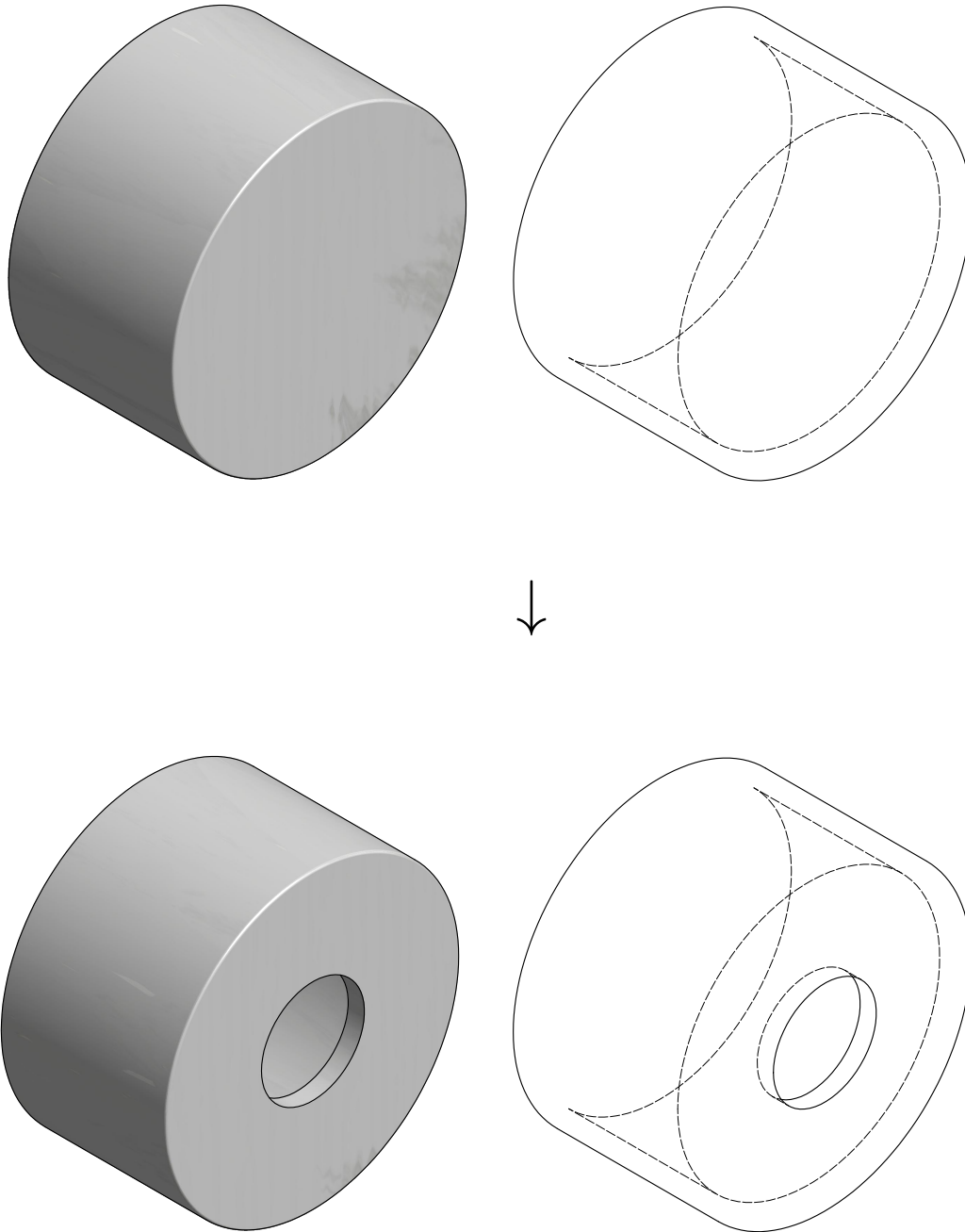

part no.

description

02

3", female socket end cap, SCH 40

Step 03: Attach end cap and adapter and cement in place.

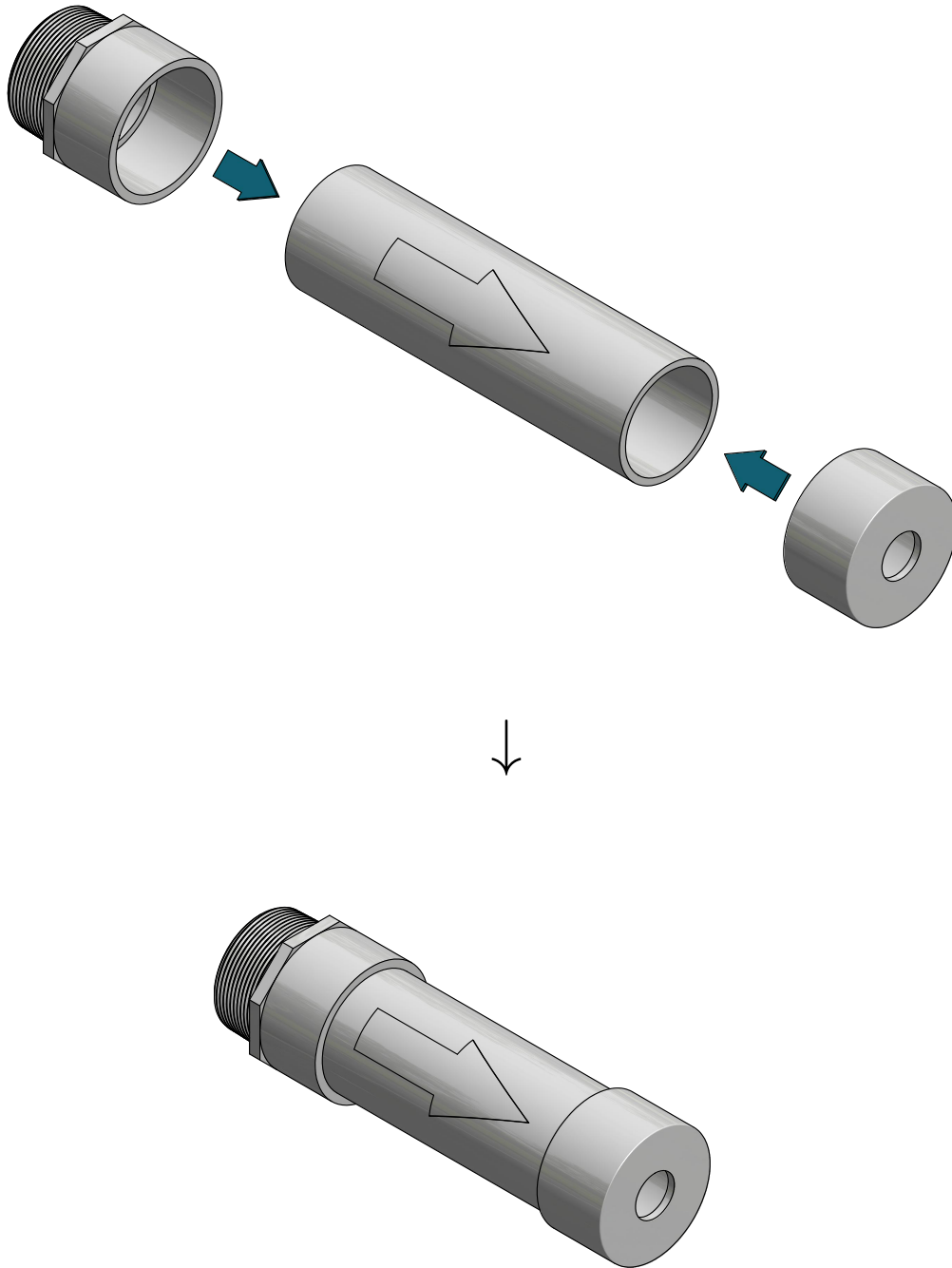

part no.

description

03

3" female socket to male thread adapter, SCH 40

Step 04: Insert 1/2", half-threaded nipple into tank connector.

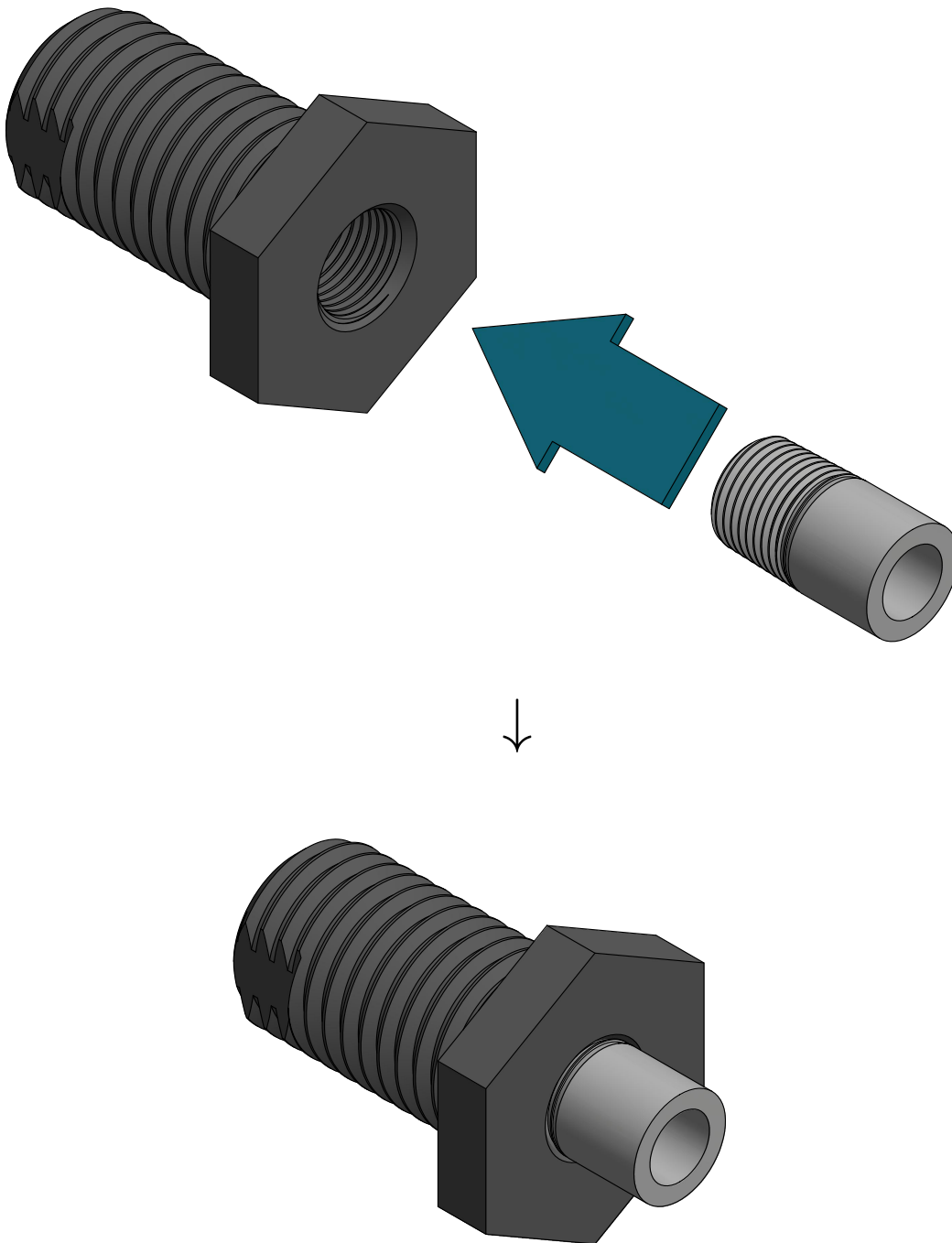

part no.	description
04	1/2" tank connector
05	1/2", half-threaded nipple, SCH 80

Step 05: Place rubber washers and pipe segment around half-nipple.

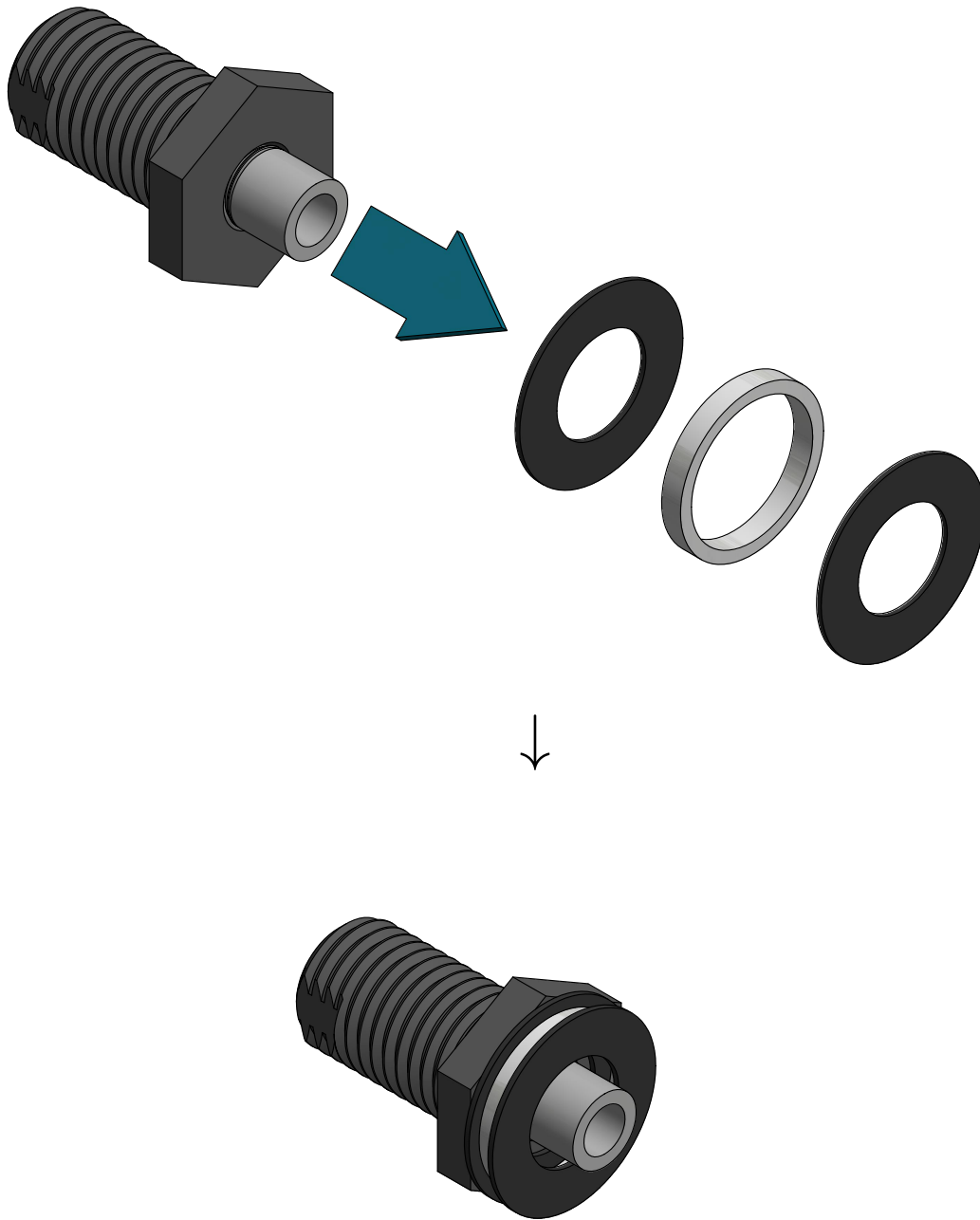

part no.	description
06	1 ¹ / ₈ " ID, 2 ¹ / ₈ " OD rubber washer
07	1 ¹ / ₂ " pipe slice, SCH 40, about 1 ¹ / ₄ " thick

Step 06: Attach tank connector gasket.

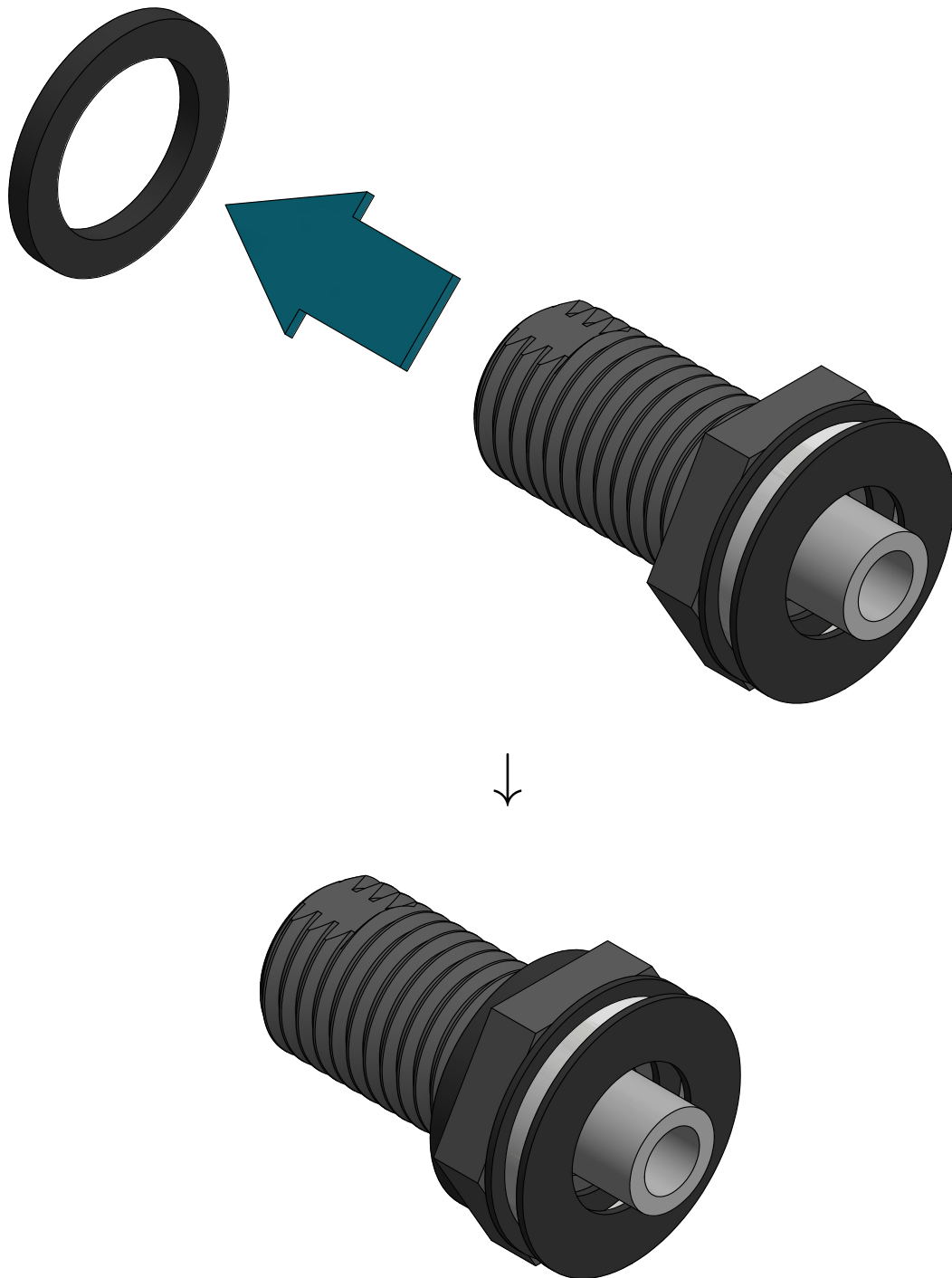

part no.

description

08

1/2" tank connector gasket

Step 07: Insert previous assembly into pipe/end cap assembly.

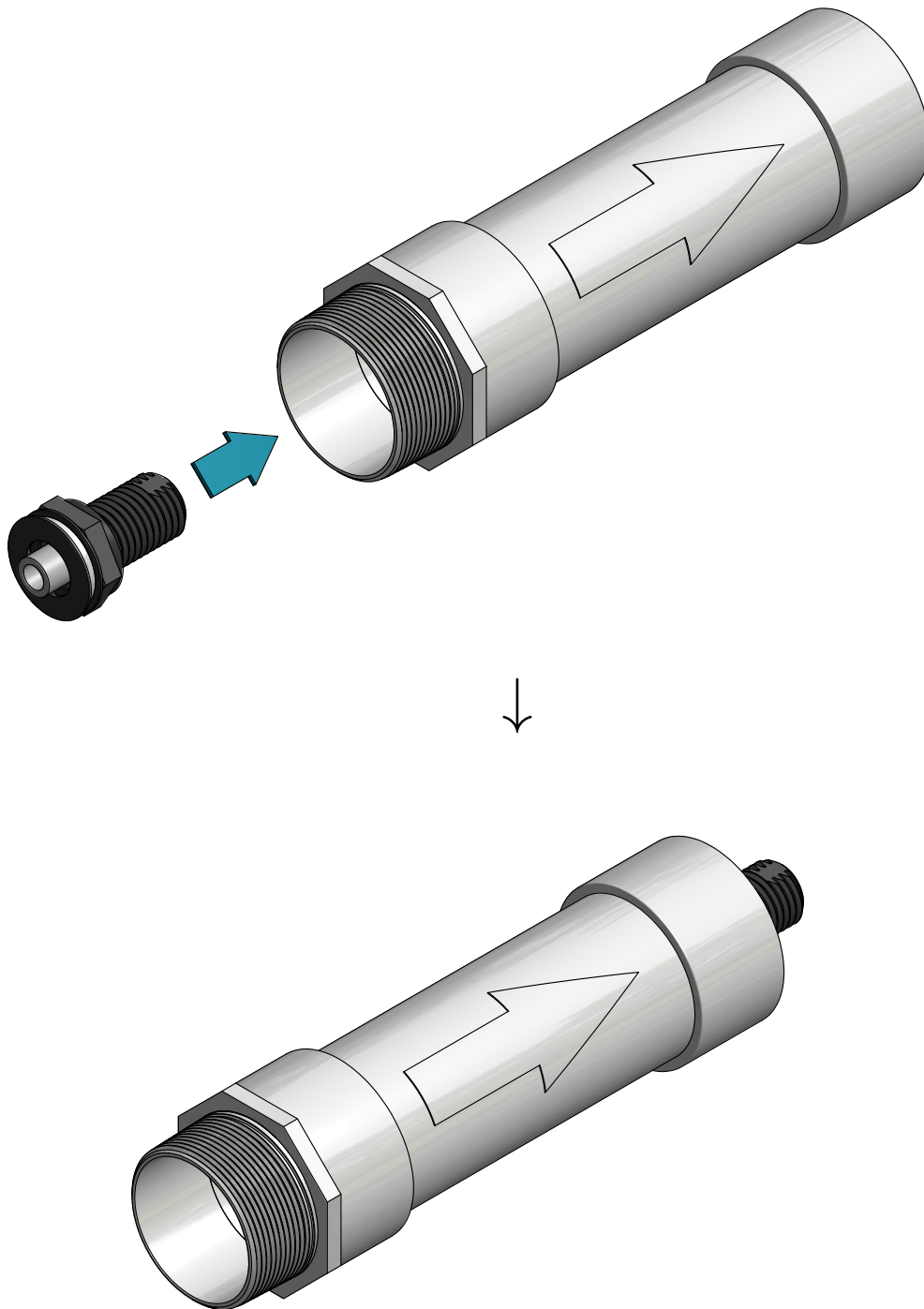

Step 08: Attach nut to tank connector.

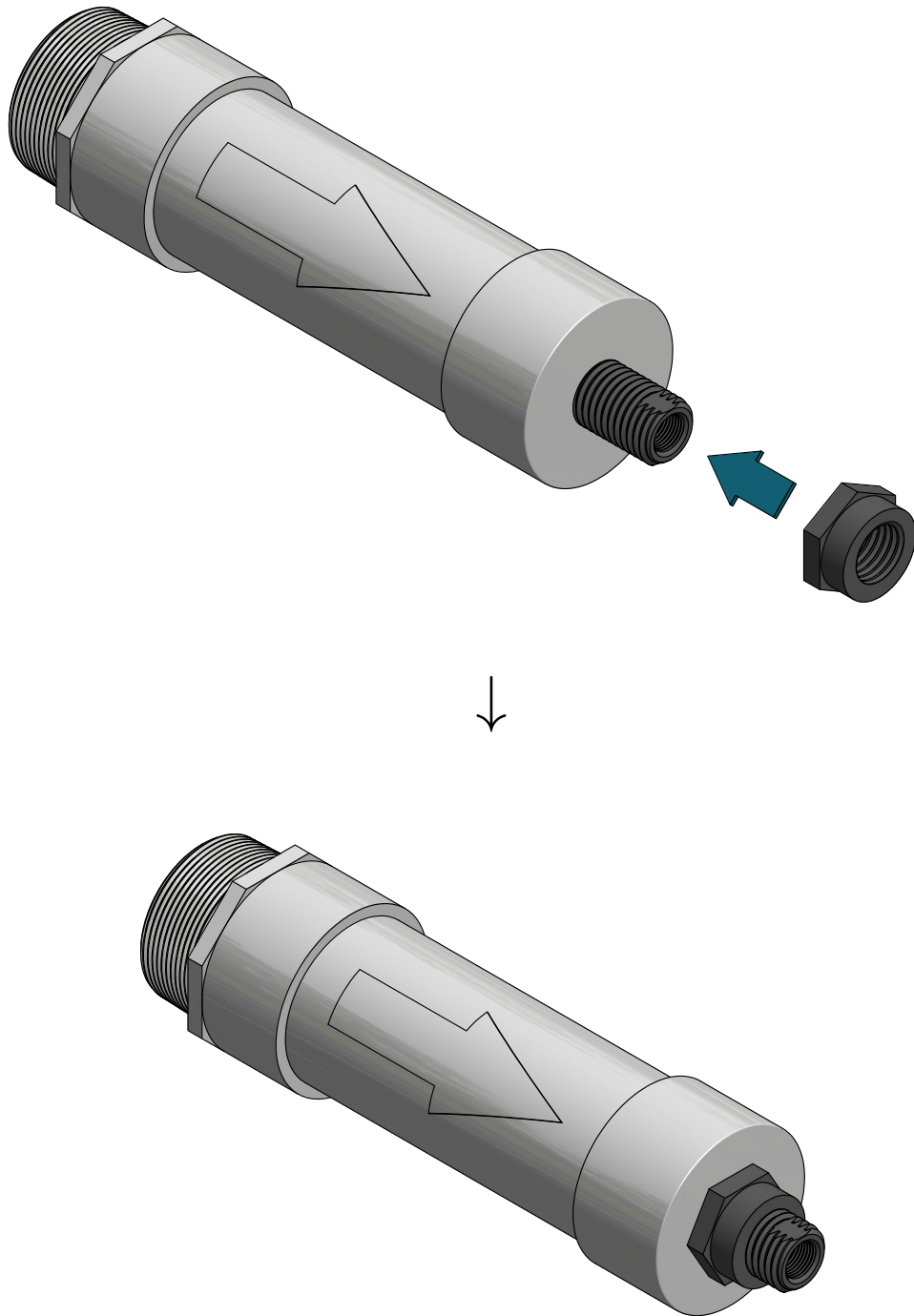

part no.

description

09

1/2" tank connector nut

Step 09: Insert carbon block filter and additional rubber washer.

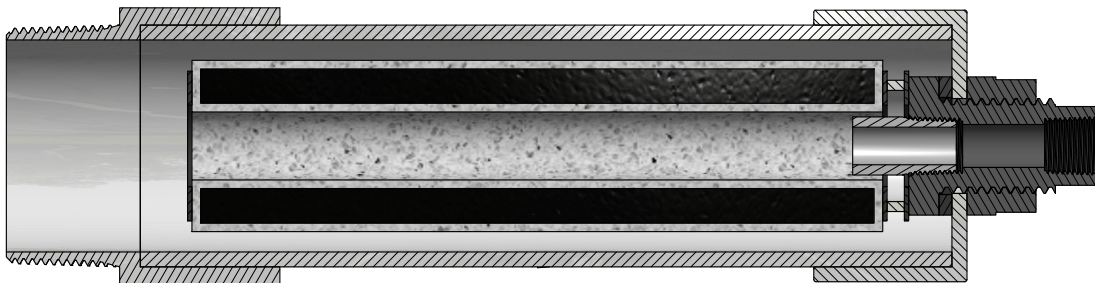
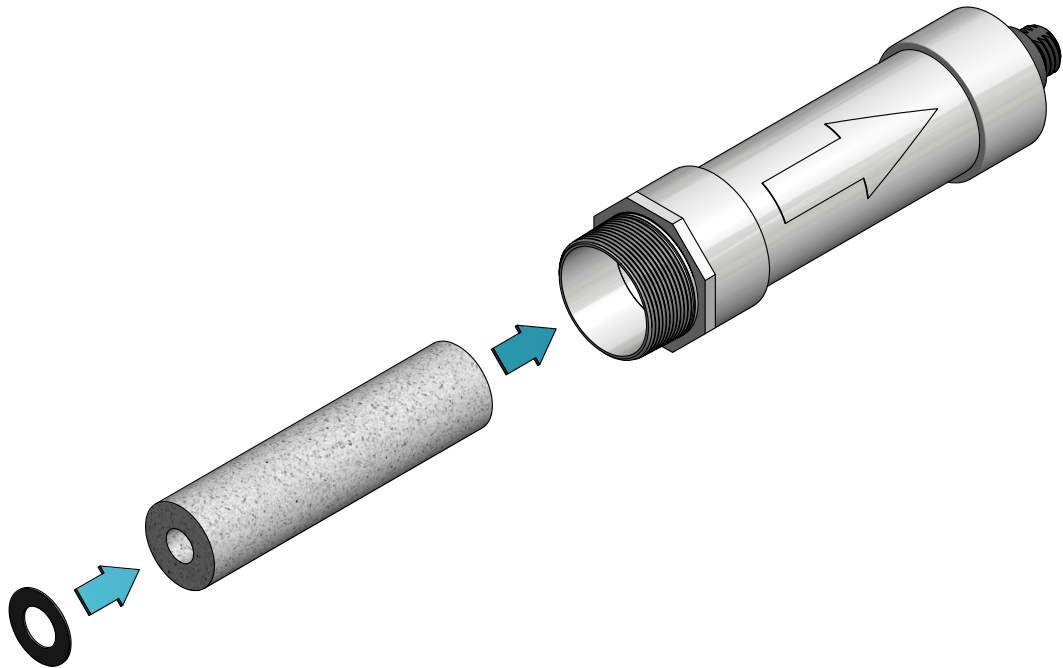

part no.	description
10	carbon block filter
06	1 ¹ / ₈ " ID, 2 ¹ / ₈ " OD rubber washer

Step 10: Drill holes in 1" female socket, 1/2" male thread adapter.

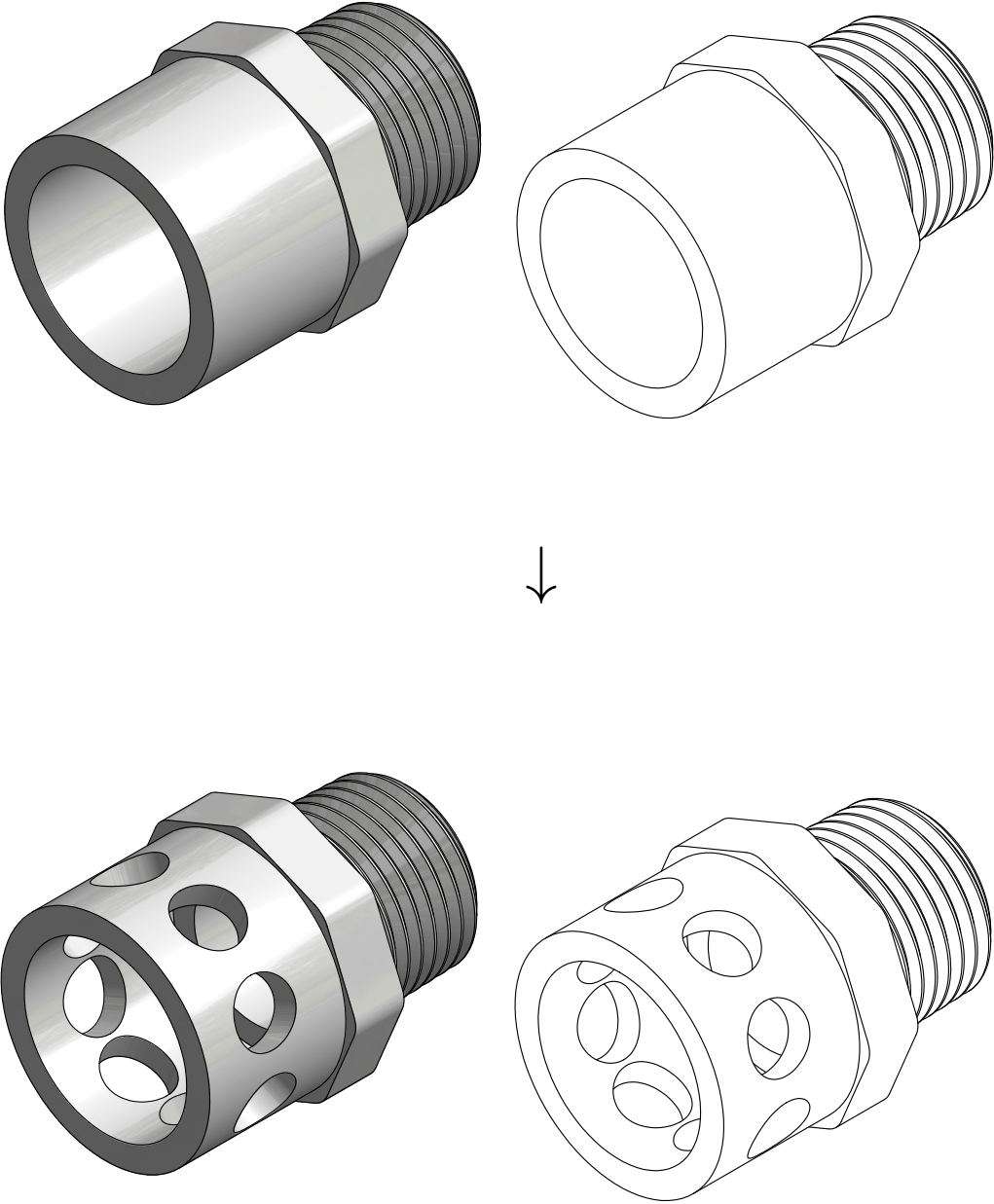

part no.

description

11

1" female socket, 1/2" male thread adapter, SCH 40

Step 11: Insert adapter into tank connector.

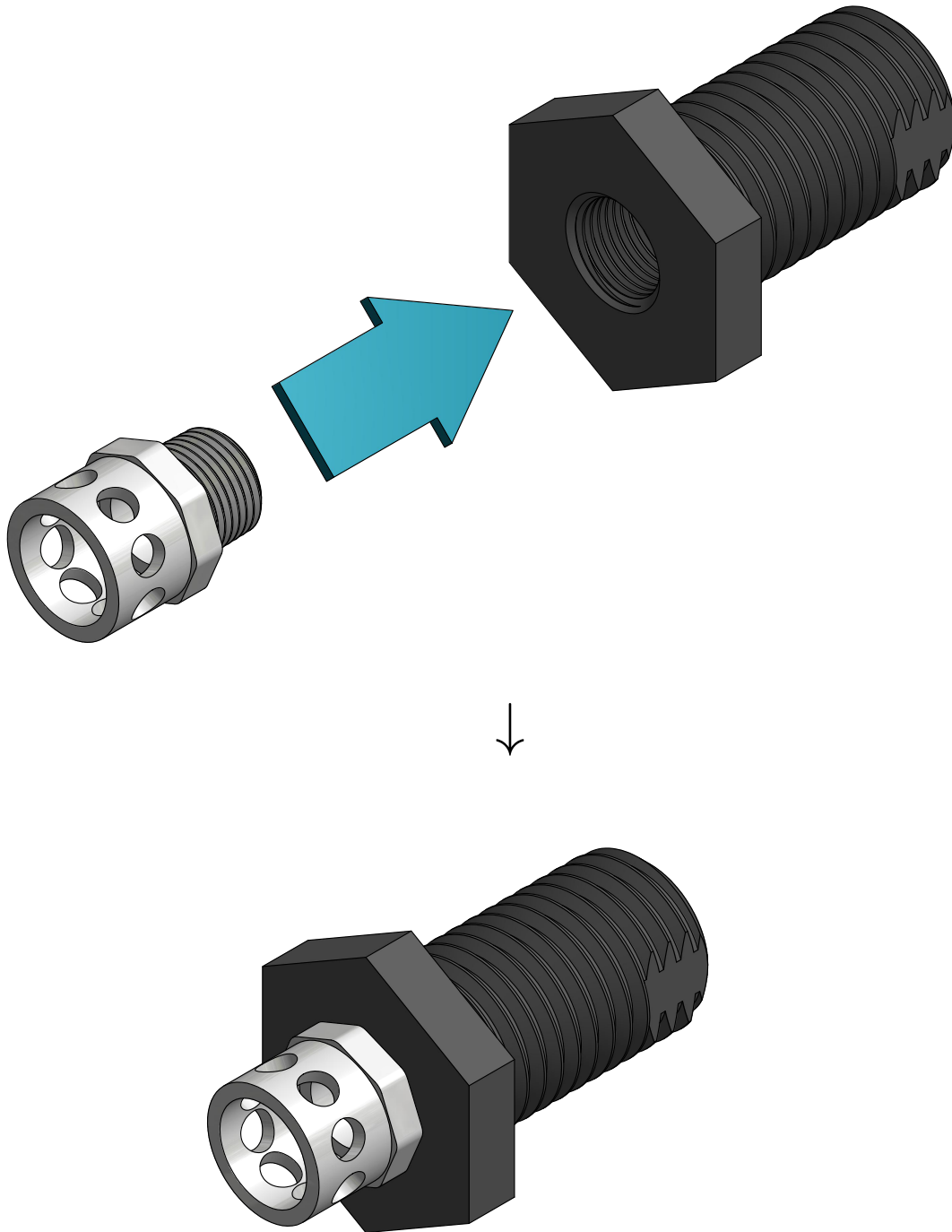

part no.

description

04

1/2" tank connector

Step 12: Drill $1\frac{3}{8}$ " inch hole in 3" female thread end cap.

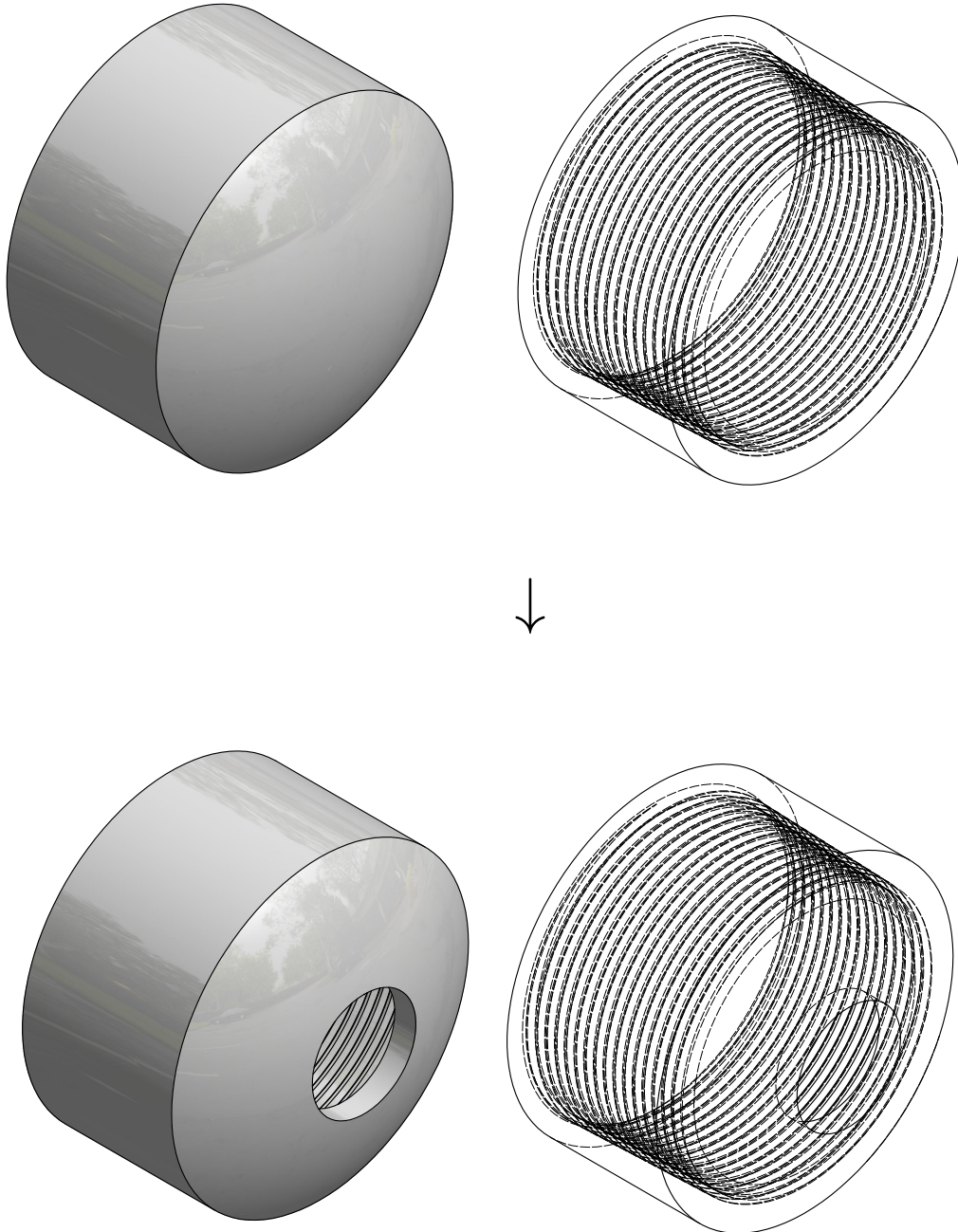

part no.

description

12

3" female thread end cap, SCH 40

Step 13: Insert 1" female socket end cap and attach previous assembly.

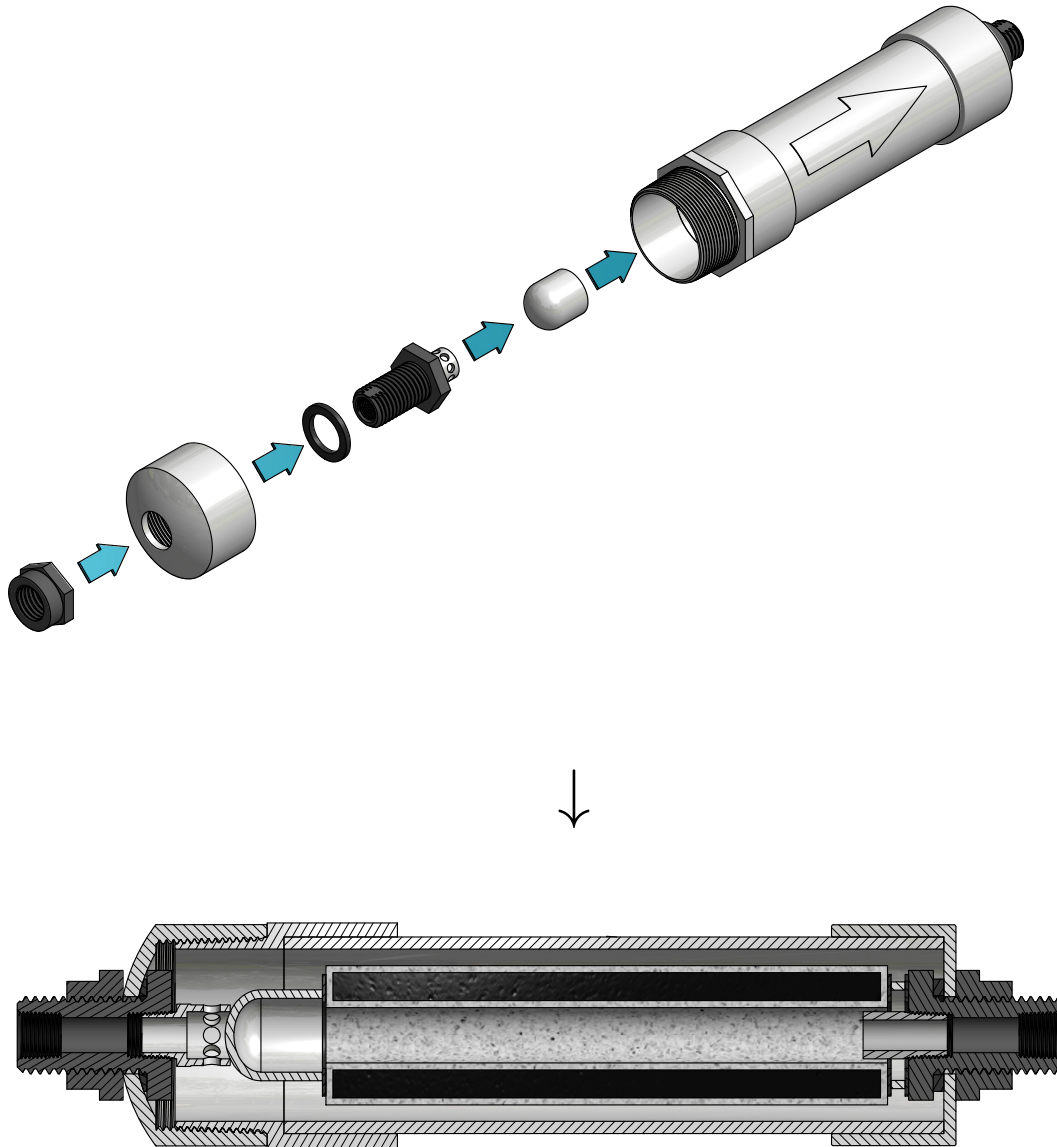

part no.

description

13

1" female socket end cap, SCH 40

Step 14: Cut slots in end of 1/2", 7" long, half threaded nipple.

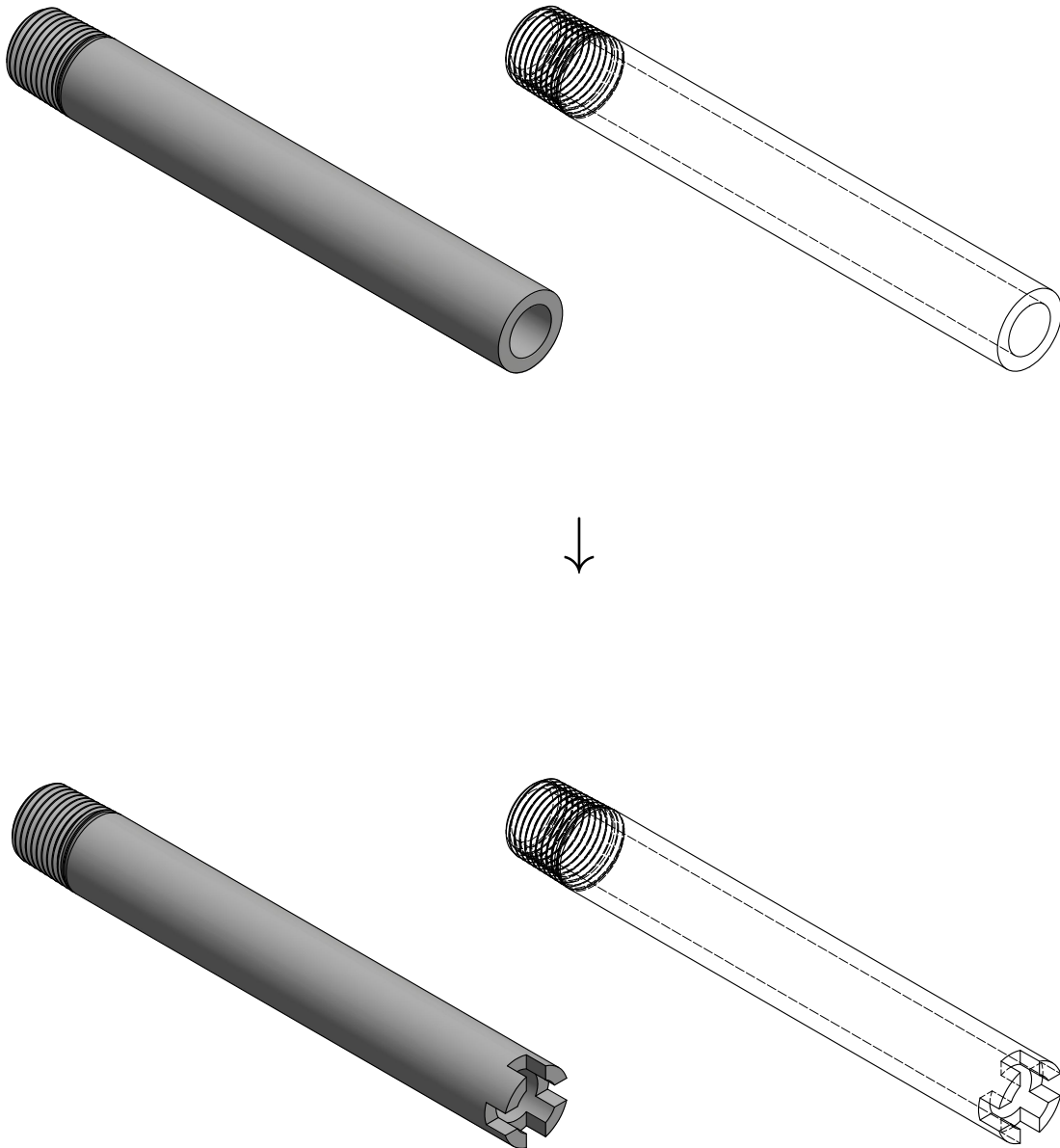

part no.	description
14	1/2", half-threaded nipple, SCH 80, 7" long

Step 15: Insert half-threaded nipple and washer into inlet of previous assembly.

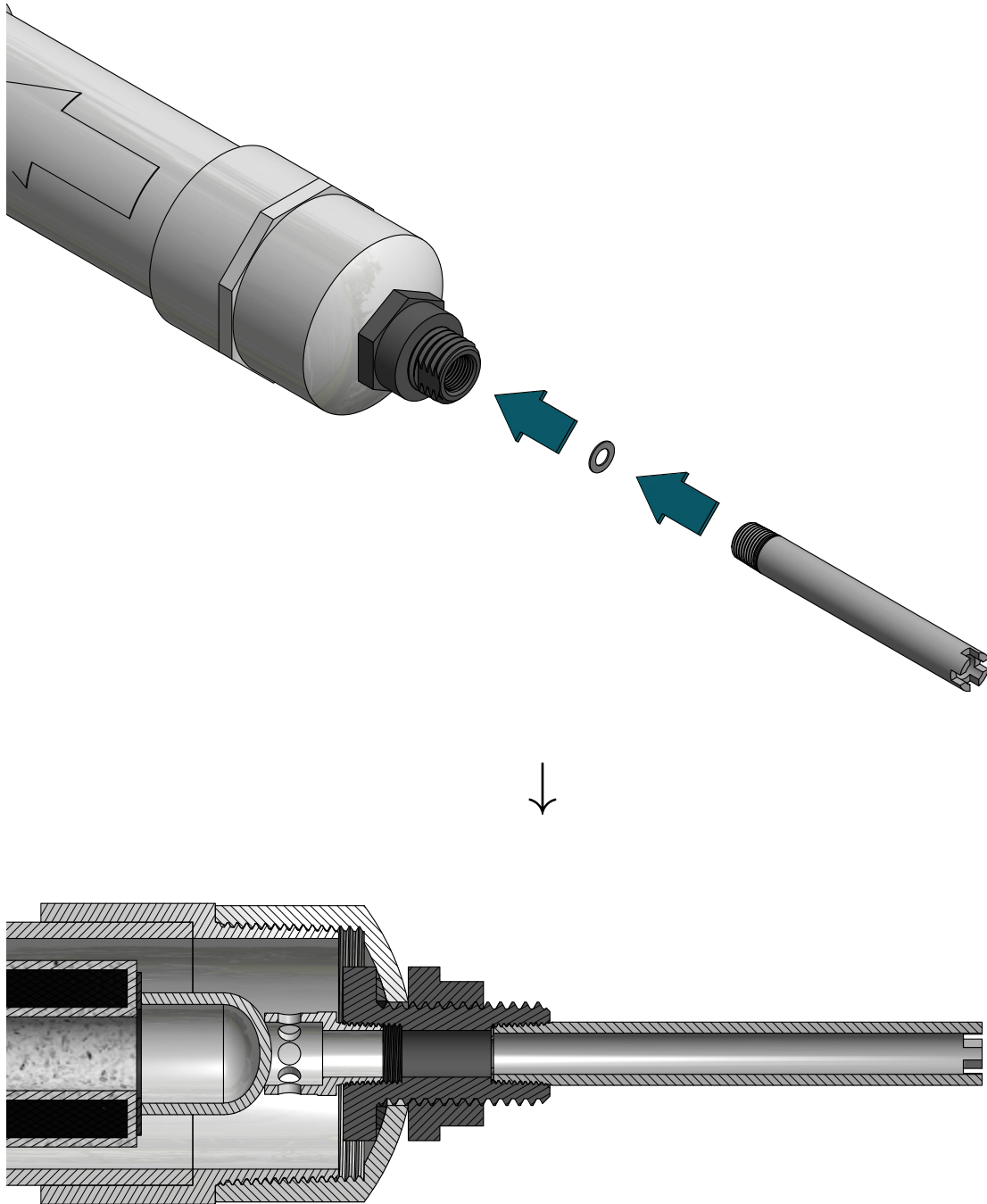

part no.

description

15

11/16" OD, 3/8" ID washer

Step 16: Insert pre-filter foam into threaded nipple.

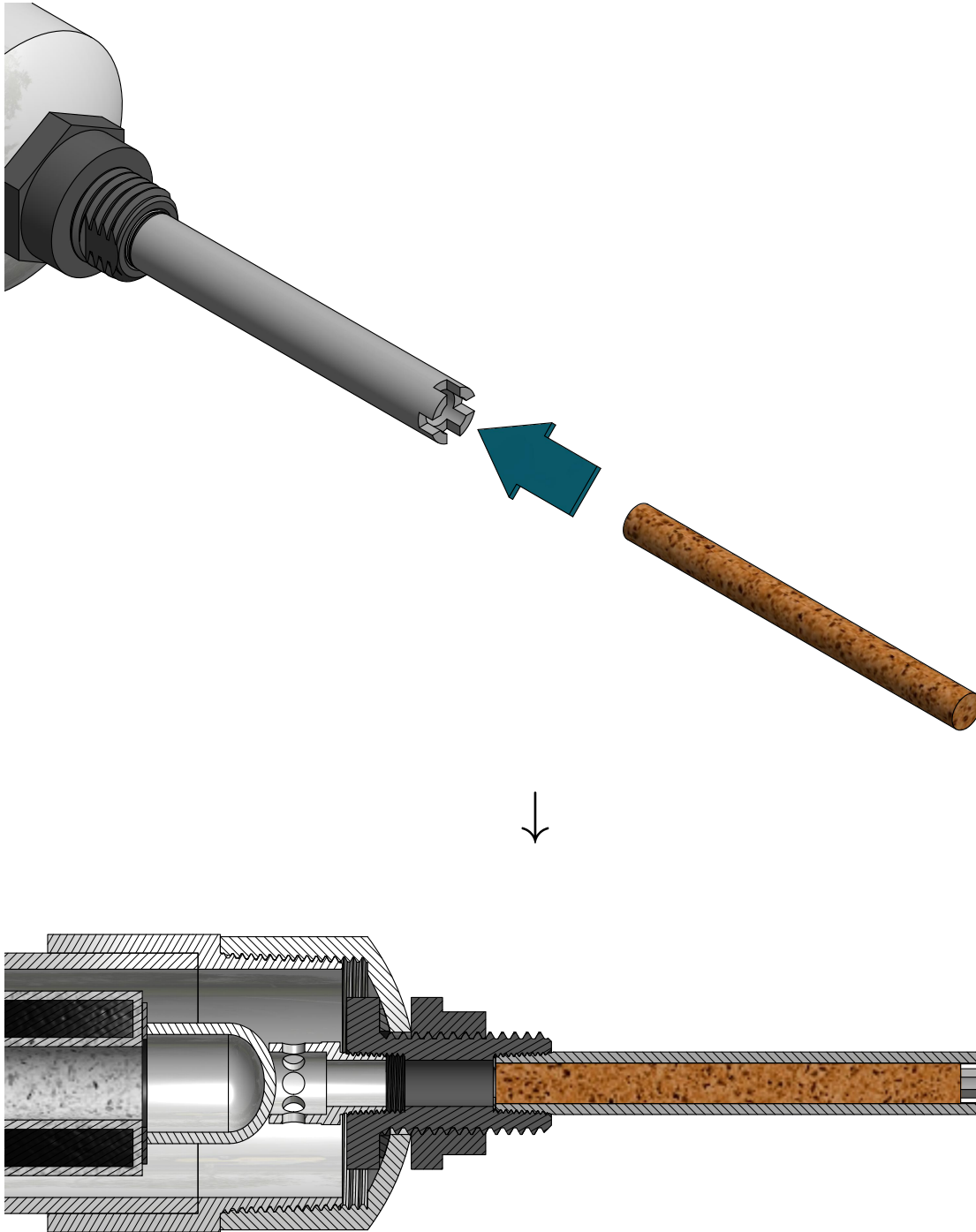

part no.

description

16

6" long piece of pre-filter foam

Step 17: Insert 1/2" close nipple and 1/2" swing check valve.

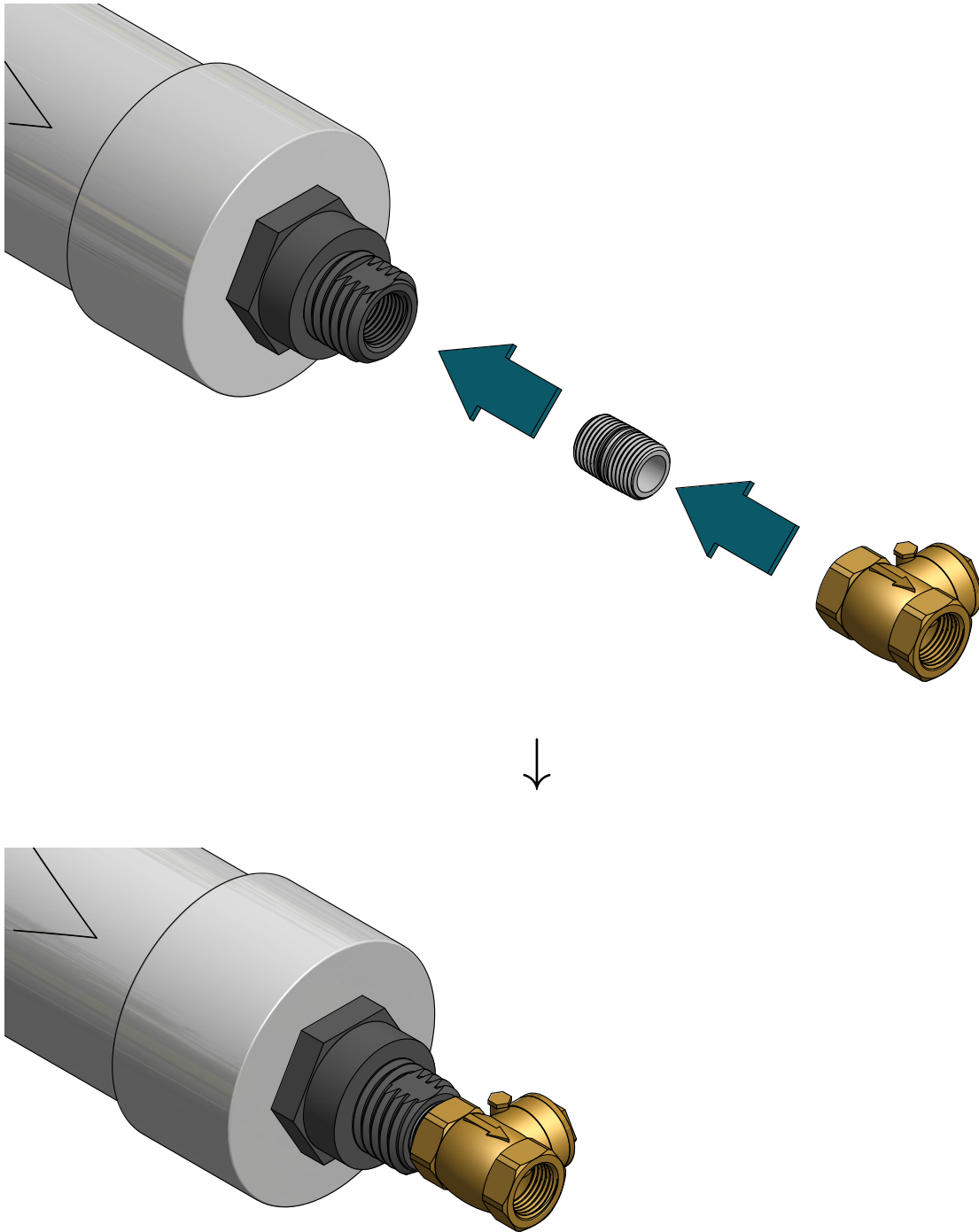

part no.	description
17	1/2" close nipple, SCH 80
18	1/2" swing check valve

Step 18: Insert another 1/2" close nipple.

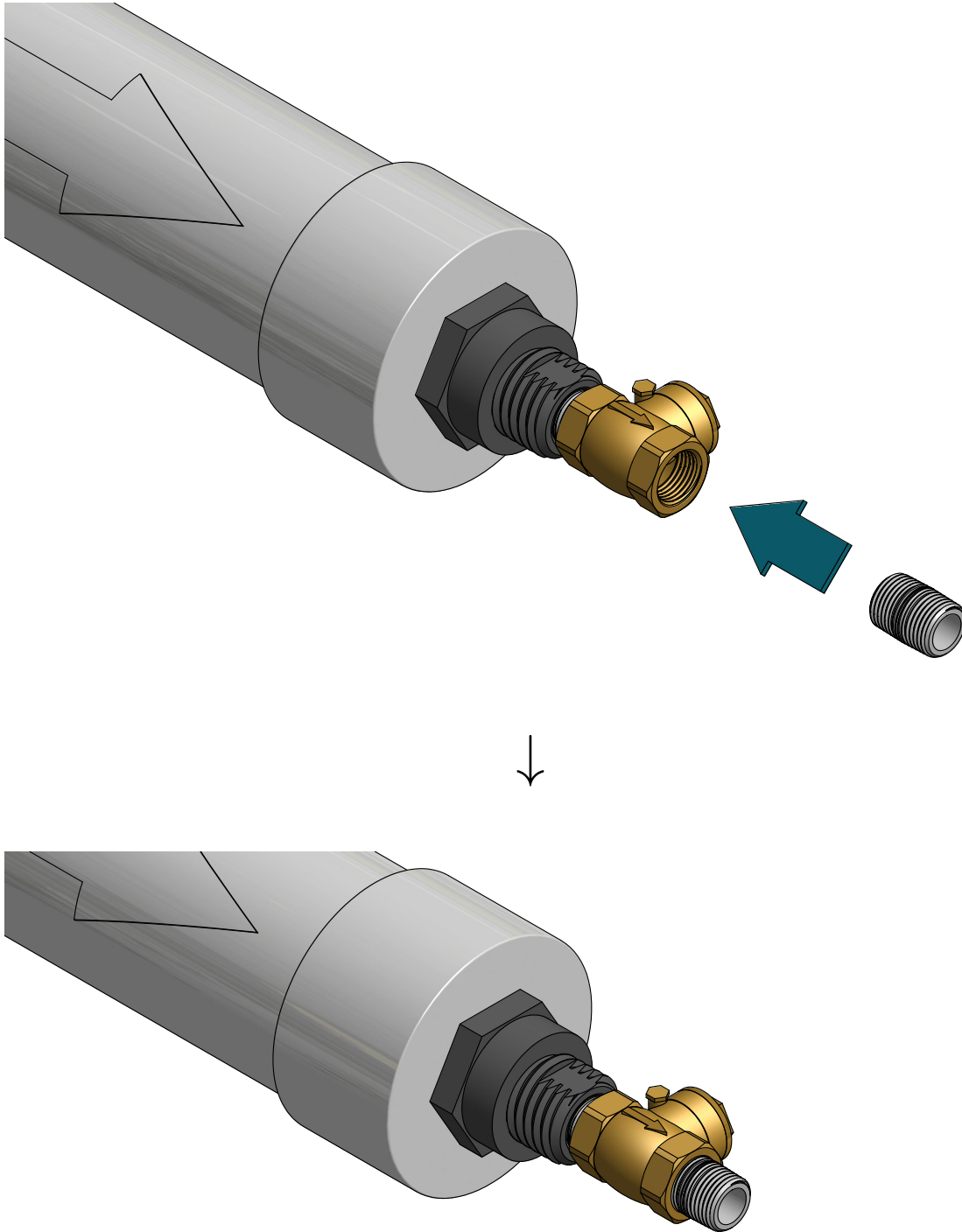

part no.

description

17

1/2" close nipple, SCH 80

Step 19: Cement two 1" male socket to 1/2" female thread bushings into tee.

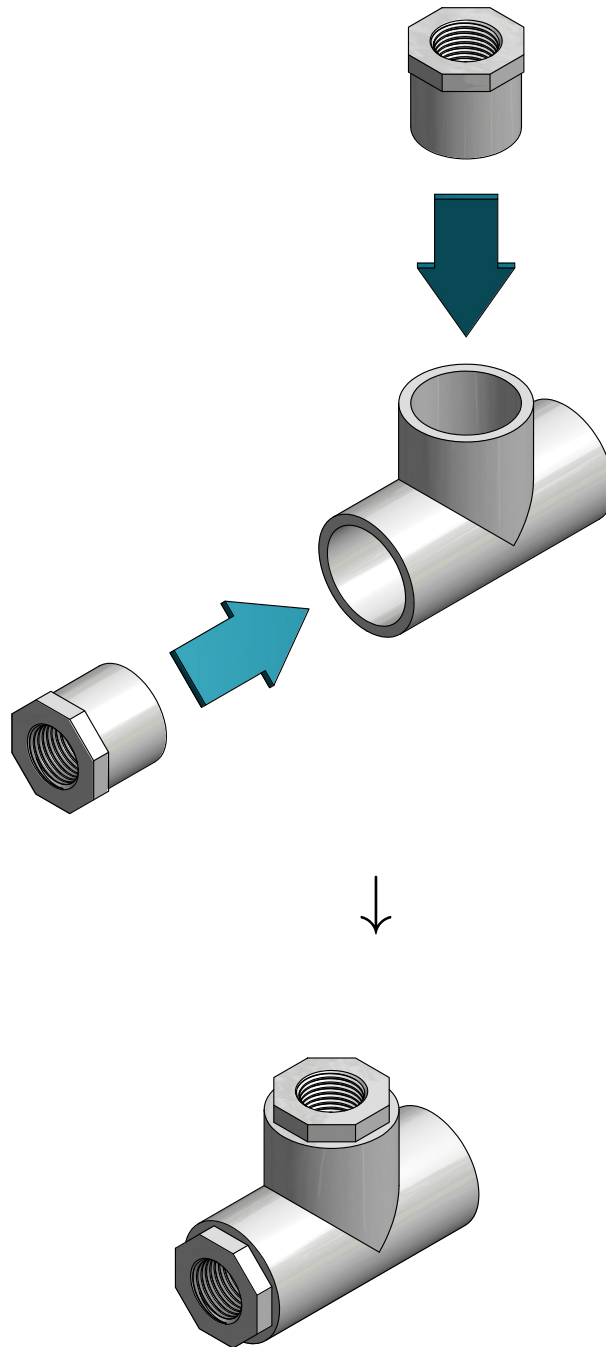

part no.	description
19	1" tee, SCH 40
20	1" male socket, 1/2" female thread bushing , SCH 40

Step 20: Insert 1", 12" long, SCH 80 pipe into other socket of tee and cement in place.

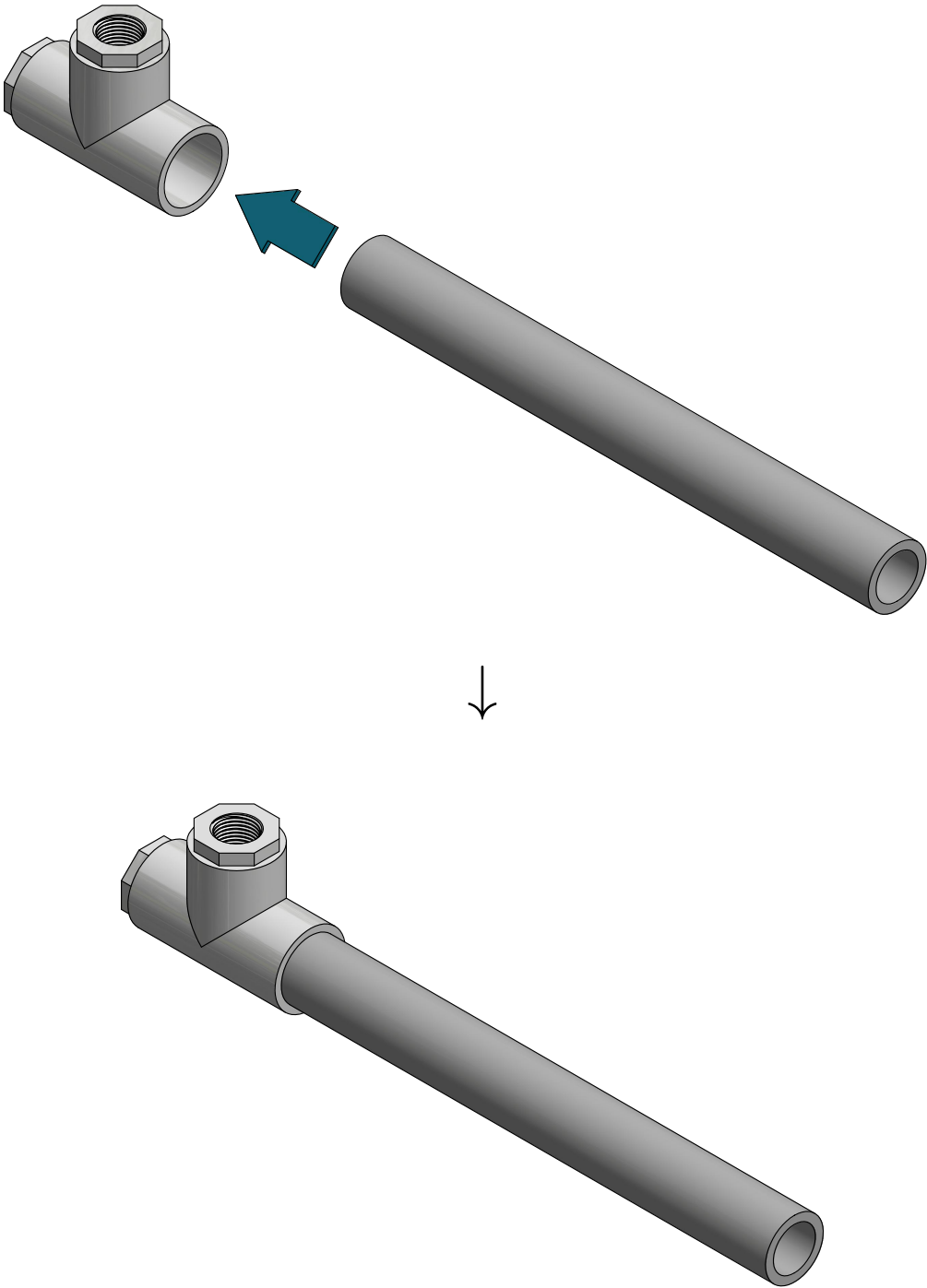

part no.	description
21	1" pipe, SCH 80, about 12" long

Step 21: Attach assembly to other end of close nipple.

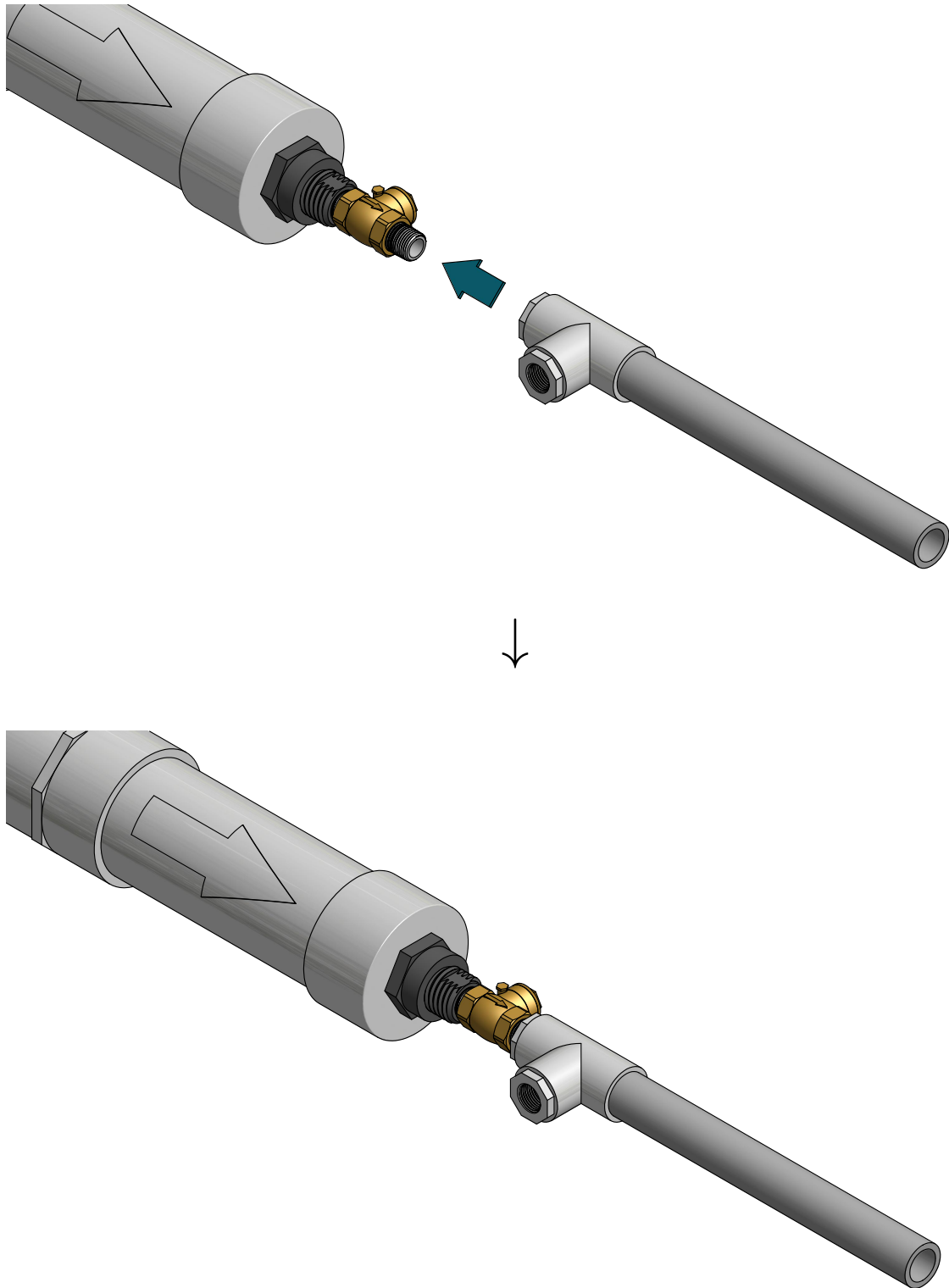

Step 22: Insert another 1/2" nipple and attach another 1/2" swing check valve.

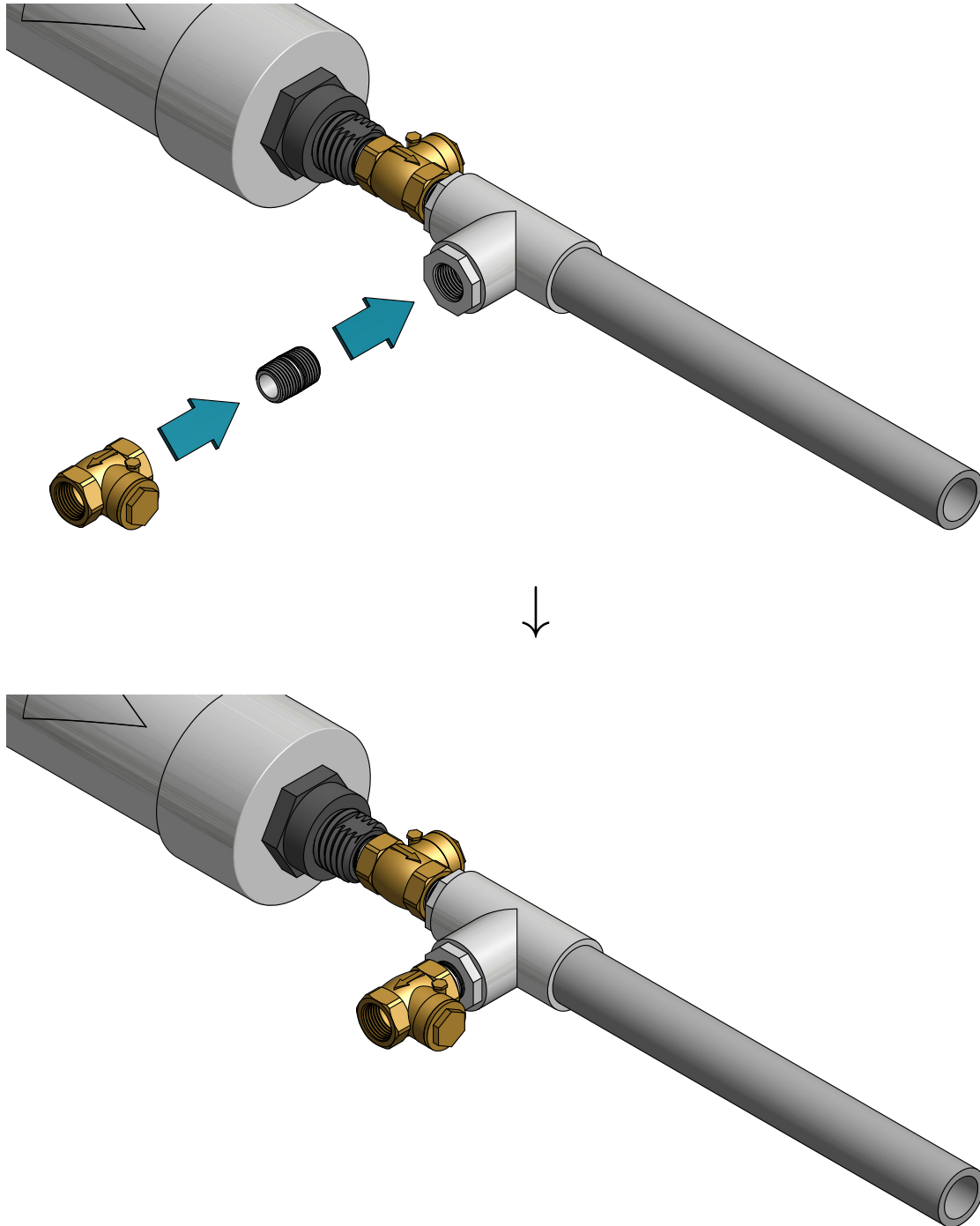

part no.	description
17	1/2" close nipple, SCH 80
18	1/2" swing check valve

Step 23: Insert 1/2" elbow and 1/2" pipe piece.

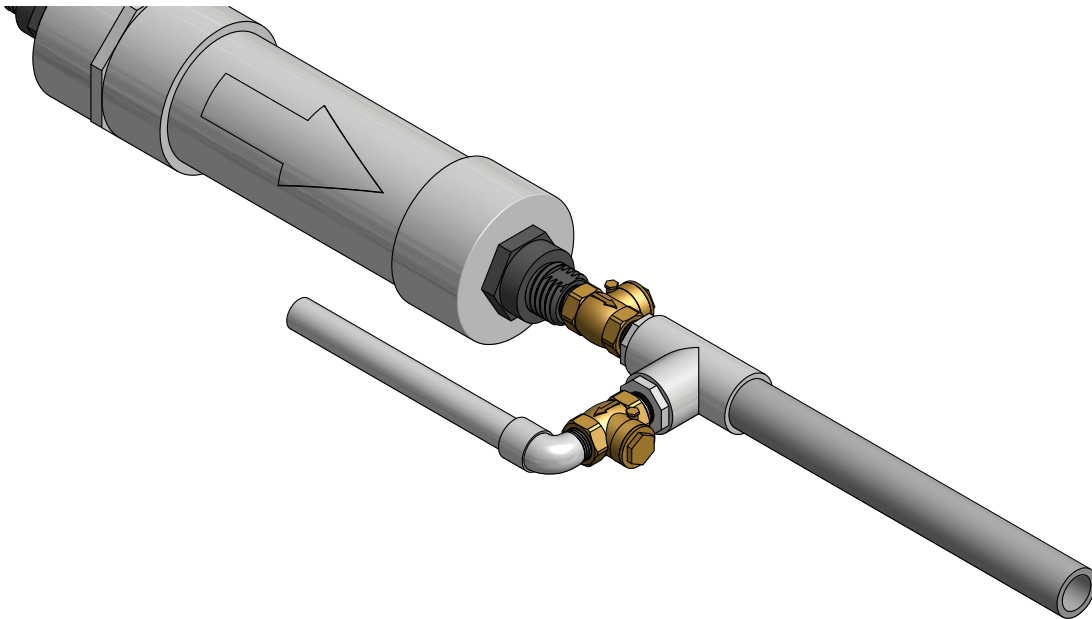
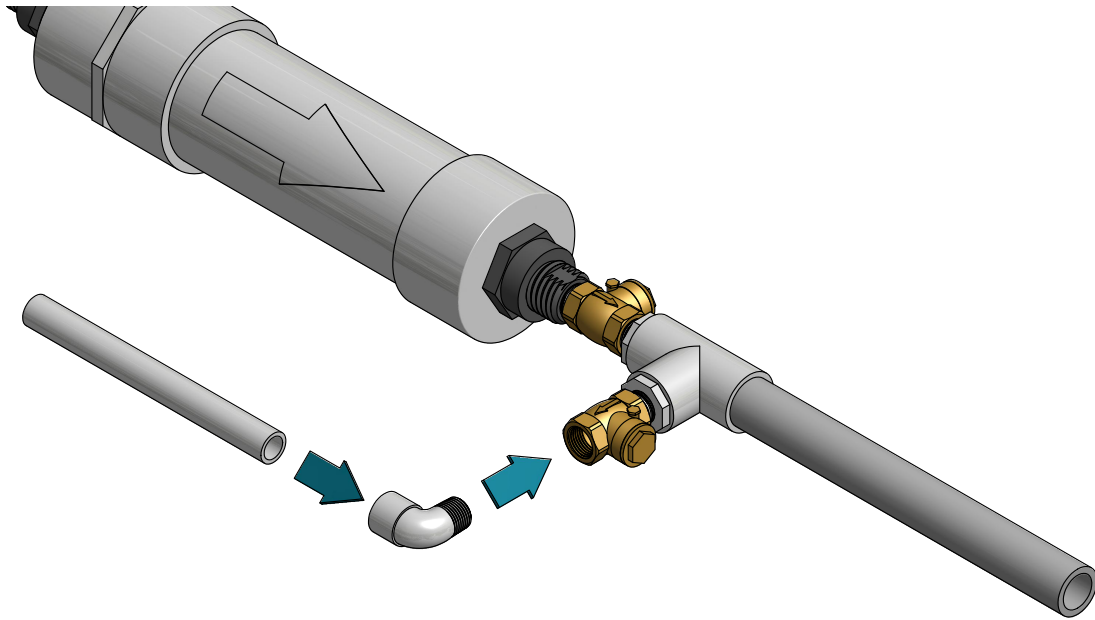

part no.	description
22	1/2" male thread, female socket elbow, SCH 40
23	1/2" pipe piece, SCH 40, about 8" long

Step 24: Cut two recesses in exterior surface of 1/2" pipe piece.

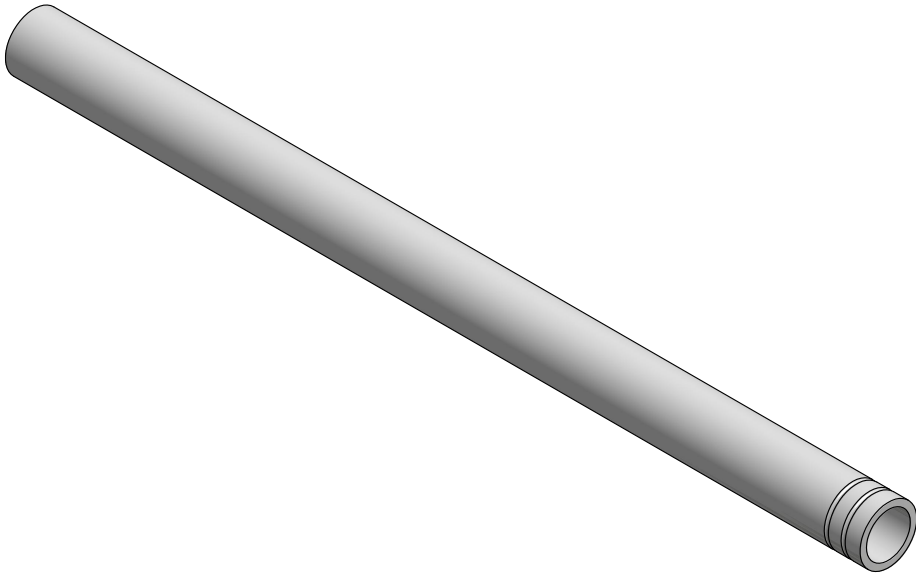
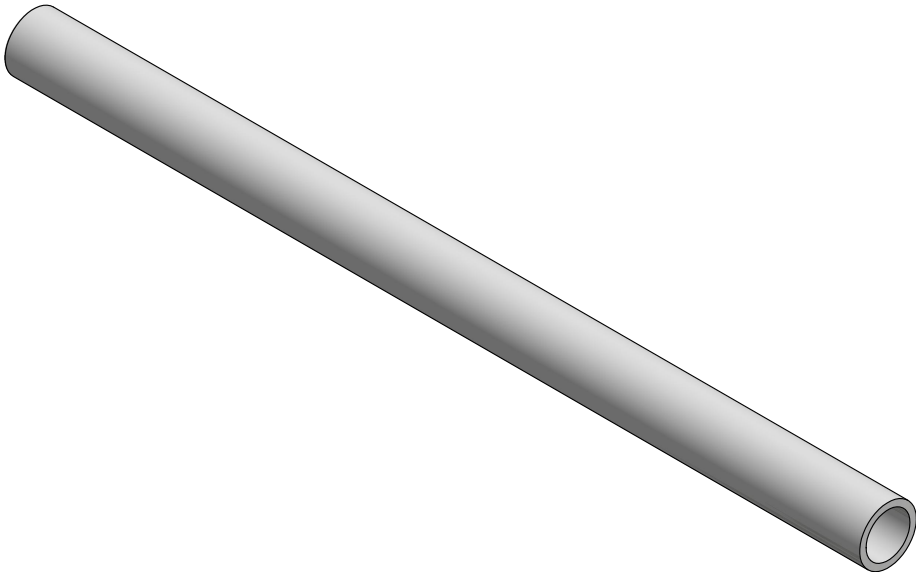

part no.	description
24	1/2" pipe piece, SCH 40, about 12" long

Step 25: Insert plug and attach O-rings to shaft.

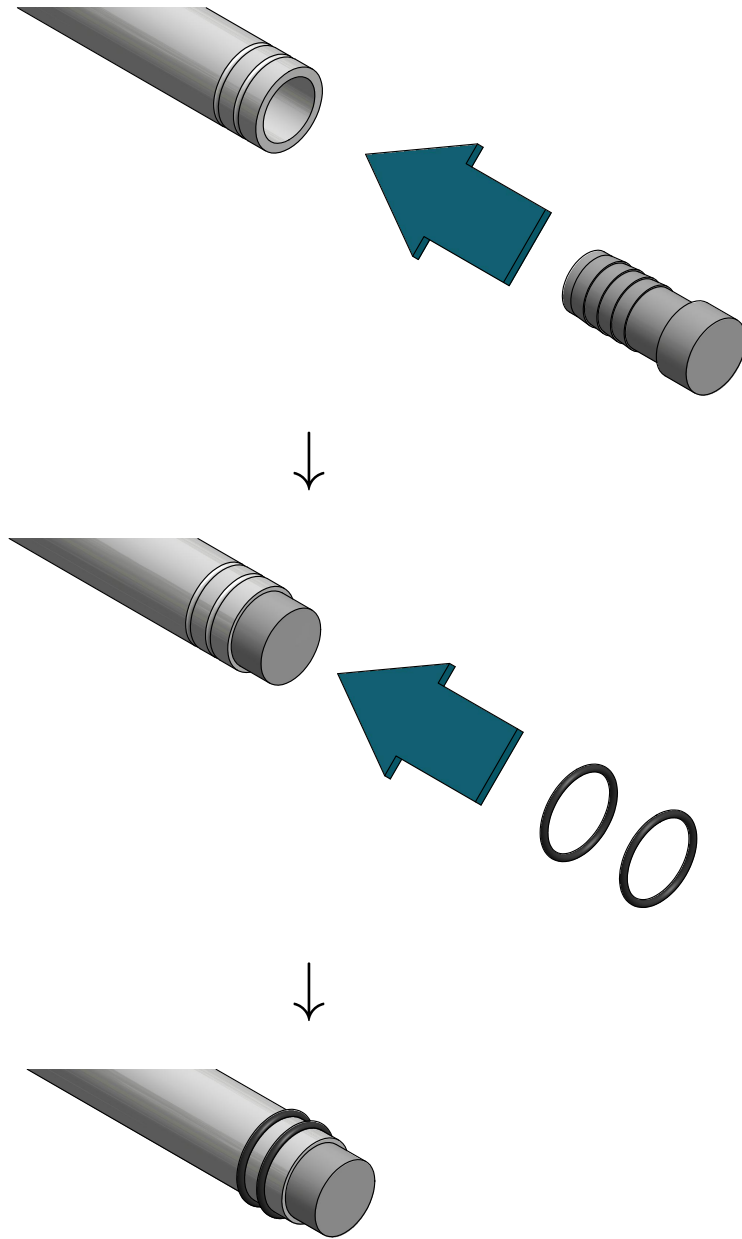

part no.	description
25	pipe plug for 1/2", SCH 40 pipe
26	O-ring, US 19

Step 26: Insert assembly into end of 1" pipe and attach O-ring.

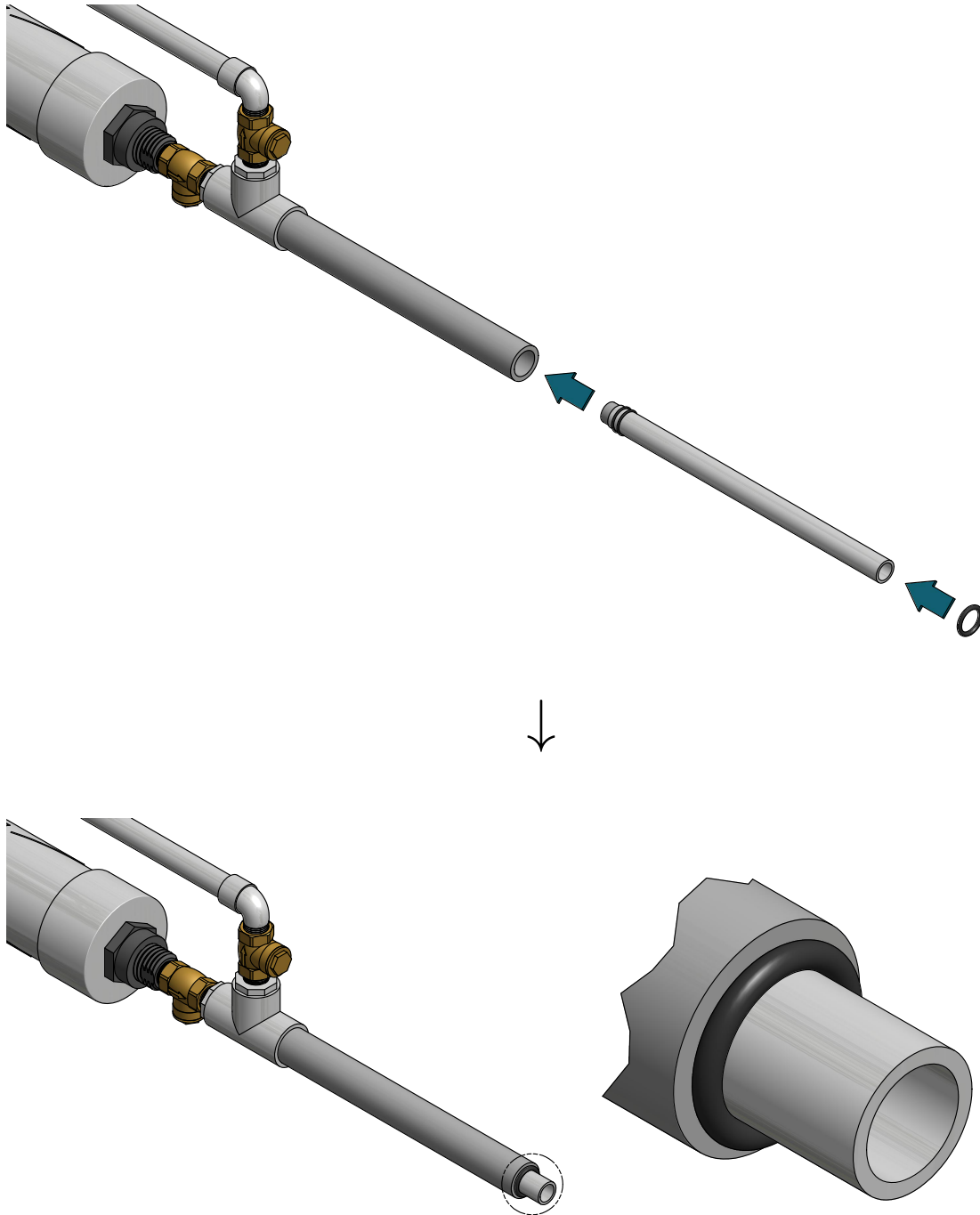

part no.

description

27

O-ring, US 267

Step 27: Drill 7/8" hole in top of 1" socket end cap.

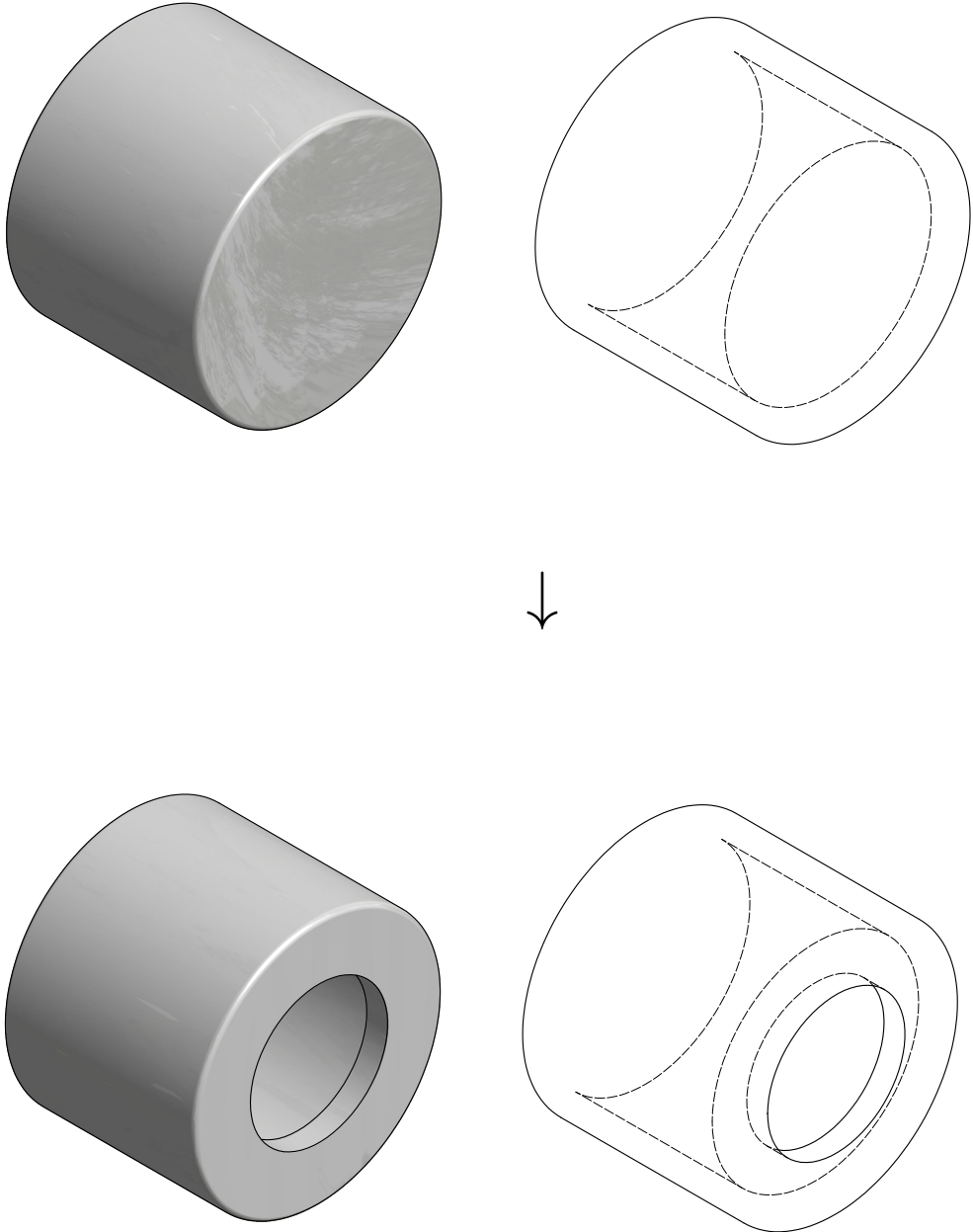

part no.

description

28

1", female socket end cap, SCH 40

Step 28: Attach cap to end of pipe.

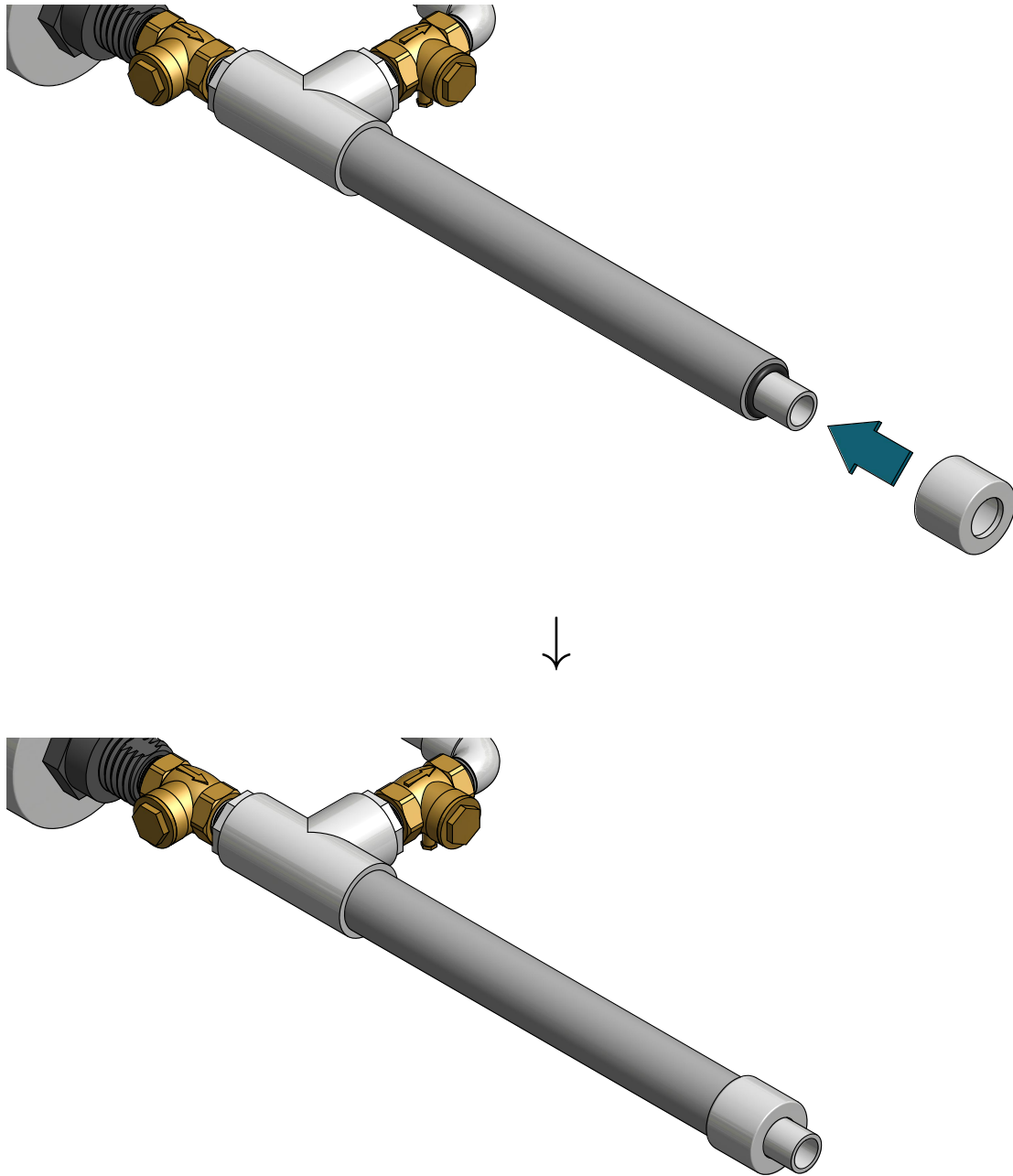

Step 29: Attach 1/2" socket tee.

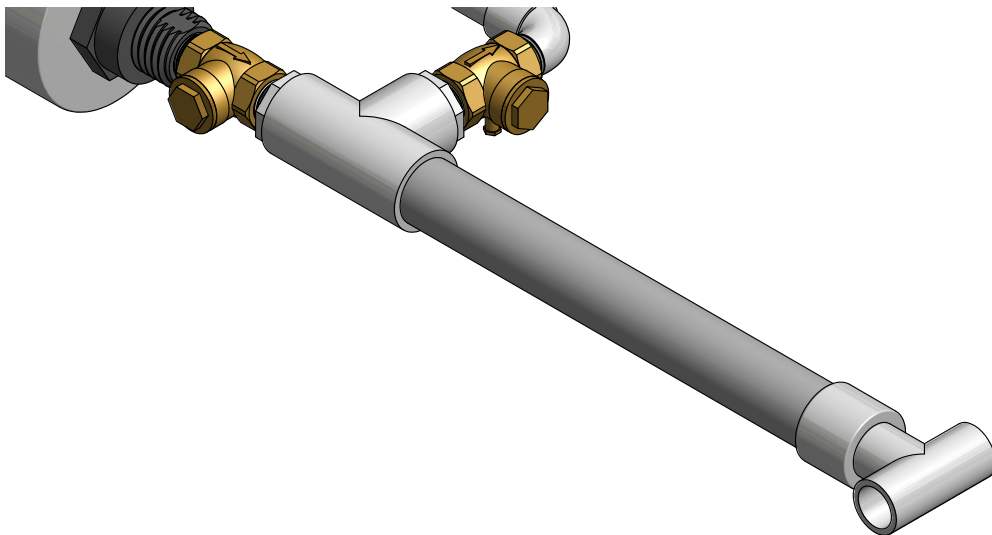
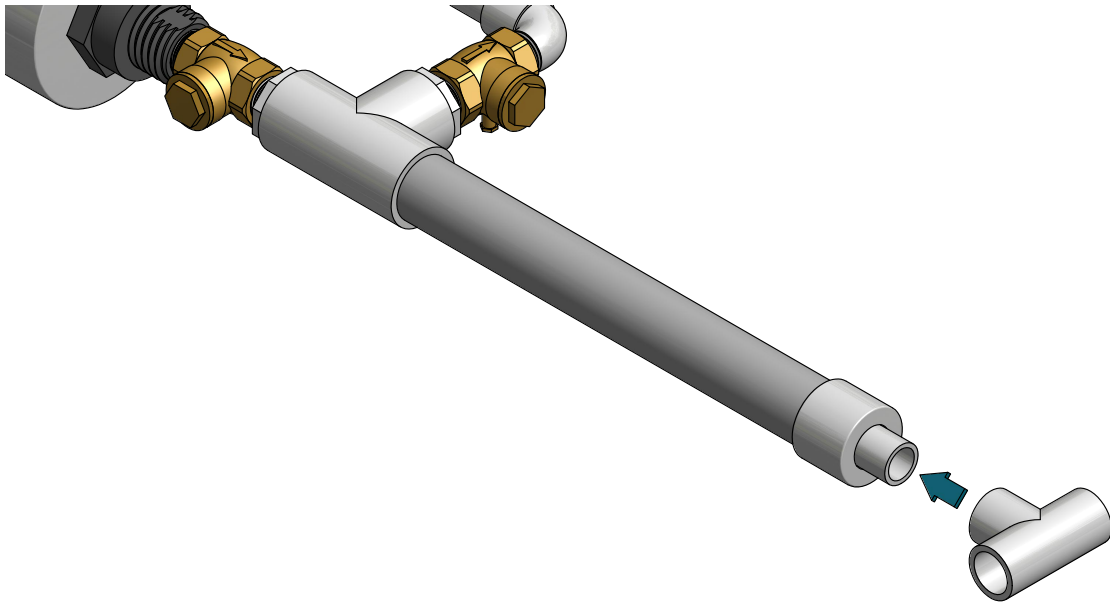

part no.

description

29

1/2" socket tee, SCH 40