

Hand-Powered Water Filter

Detail and Assembly

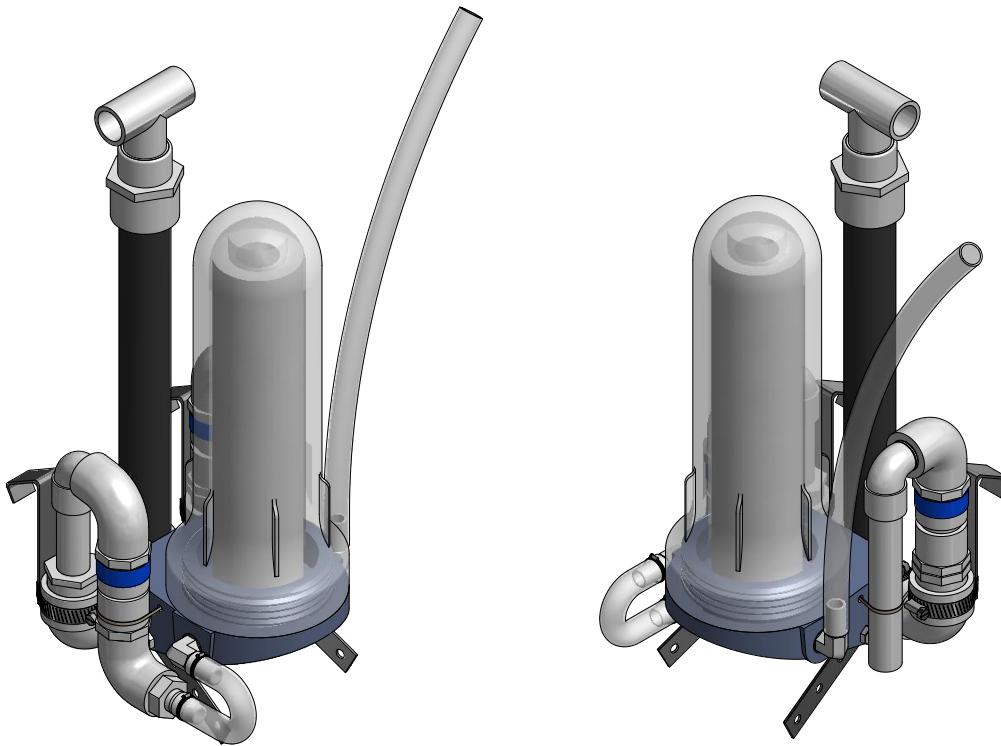

Model 1.01

Patent Pending

Last Updated August 14, 2017

Christopher Bulkley - Logston

Kaylea Brase

Sushant Bamane

Demo View

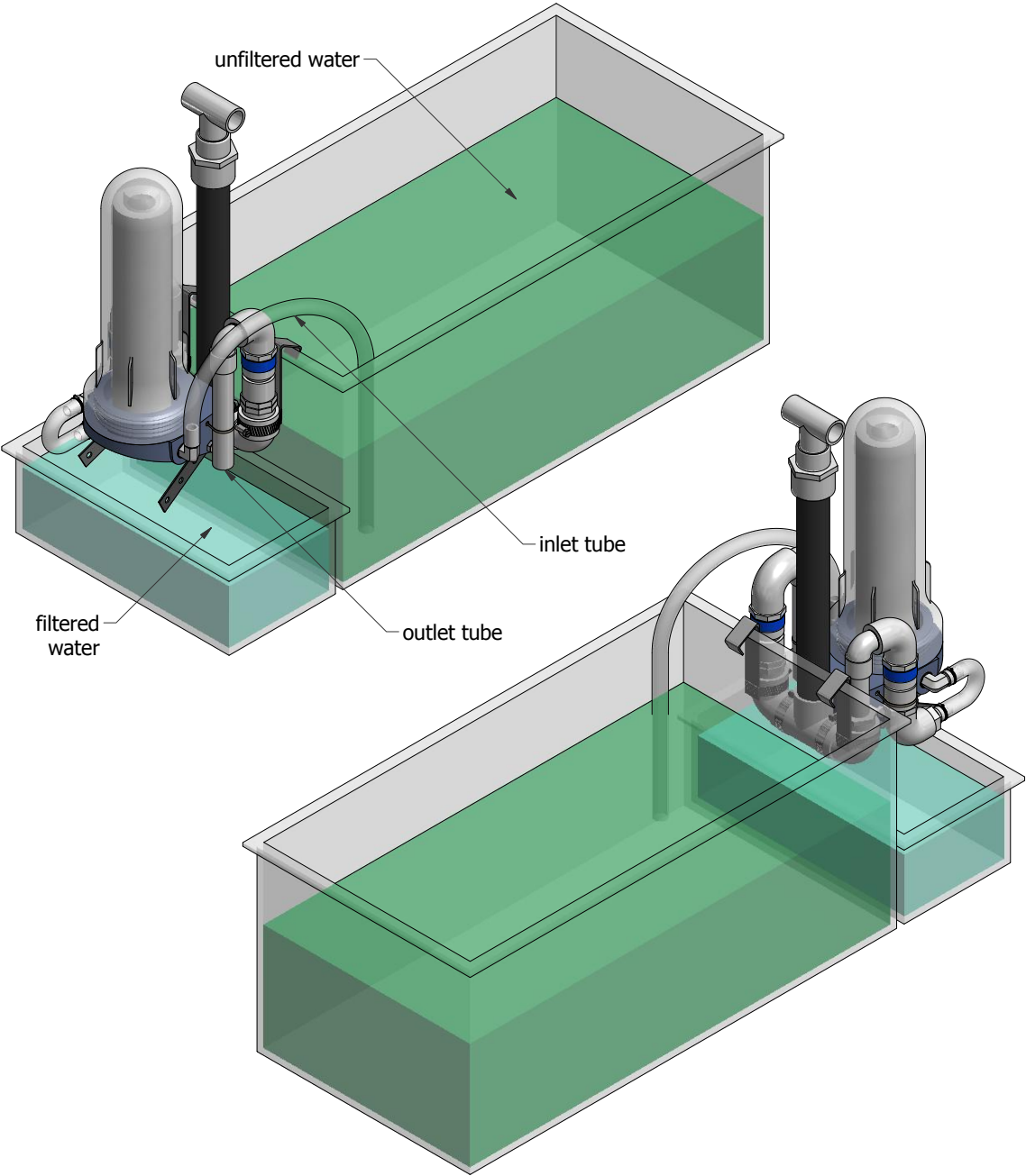

Parts List

part no.	description	dimensions	material	qty
1	pipe piece	3/4", 4cm long	PVC - sch. 40	2
2	nail with head cut off	different gauges work, 0.125 cm \varnothing shown, 1" long	non-rusting metal	2
3	standard marble	1/2" \varnothing	glass	2
4	rubber washer	7/16" ID, 1" OD, 1/16" thickness	rubber	2
5	reducer	3/4" unthreaded female to 1/2" threaded male	PVC, sch. 40	4
6	pipe piece	1/2" \varnothing , 35 cm long	PVC - sch. 40	1
7	o-ring	#14 - 15/16" OD, 3/4" ID	PTFE	2
8	barbed plug	for ID of 1/2" sch. 40 pipe	PVC	1
9	adapter	1" unthreaded female to 3/4" threaded female	PVC - sch. 40	1
10	handle tee	1/2" all ends unthreaded	PVC - sch. 40	1
11	tee, female	1", 1 end threaded, 2 ends unthreaded	PVC - sch. 40	1
12	elbow, male to female	1", both ends unthreaded	PVC - sch. 40	2
13	bushing	1" unthreaded male to 1/2" threaded female	PVC - sch. 40	1
14	bushing	1" unthreaded male to 1/2" unthreaded female	PVC - sch. 40	1
15	pipe piece	1/2", ~ 9 cm long	PVC - sch. 40	1
16	hose clamp	for ~ 1 1/2" \varnothing	non-rusting metal	2
17	metal bar/strip	3/4" wide, ~ 4.25" long	non-rusting metal	2
18	nut	1/4" - 20	non-rusting metal	4
19	bolt	1/4" - 20, 3/4" long	non-rusting metal	4
20	barbed elbow	match male threading to filter head, barbed outlet for tube of 1/2" ID	PVC or nylon	2
21	male-female elbow	1/2", threaded male to unthreaded female	PVC, sch. 40	1
22	female-female elbow	1/2", female-female threaded	PVC sch. 40	1
23	barbed fitting	1/2" male threaded to barbed outlet for tube of 1/2" ID	nylon	1
24	flexible tube	1/2" ID, ~ 5" long	polyvinyl	1
25	hose clamp	for ~ 3/4" \varnothing	non-rusting metal	2
26	pipe piece	1/2", 14cm long	PVC - sch. 40	1
27	threaded nipple	1" \varnothing , 14cm long	PVC - sch. 80	1
28	bent clip	bend according to container, unbent length ~ 4.25"	non-rusting metal	2
B1	filter bowl head	manufactured	plastic	1
B2	filter bowl	premanufactured length	plastic	1
B3	filter cartridge	10" standard nominal length	-	1

Parts View

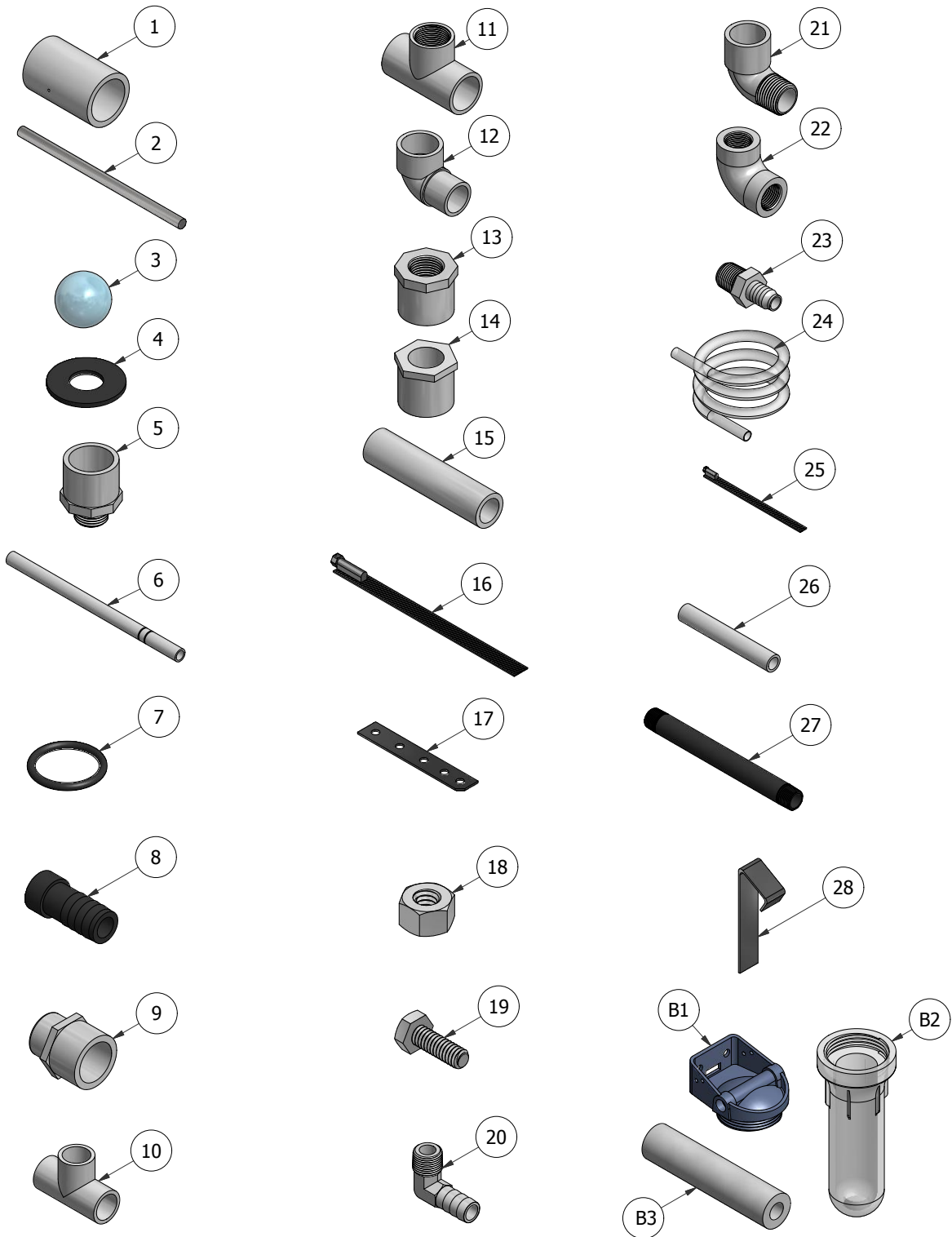

Step 01: Drill holes in pipe piece and insert nail.

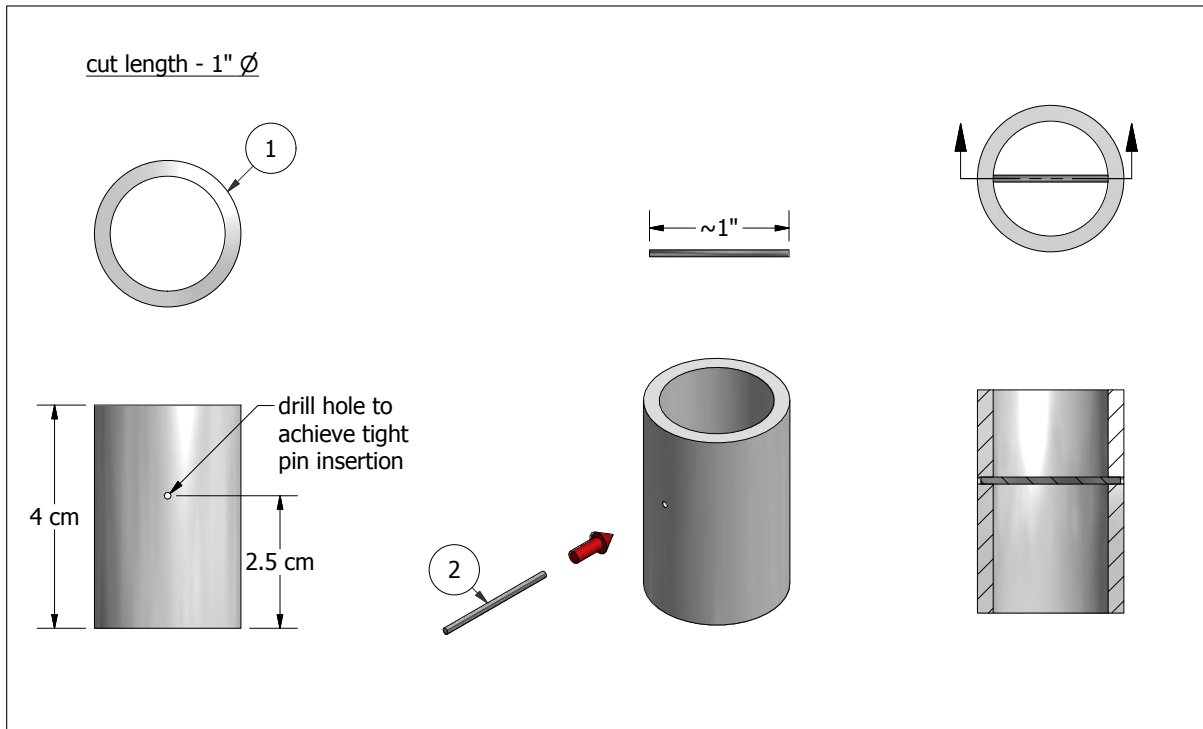

part no.	description	dimensions	material	qty
01	pipe piece	3/4", 4cm long	PVC - sch. 40	1
02	nail with head cut off	different gauges work, 0.125 cm \varnothing shown, 1" long	non-rusting metal	1

Step 02: Drop rubber washer and marble into a reducer.

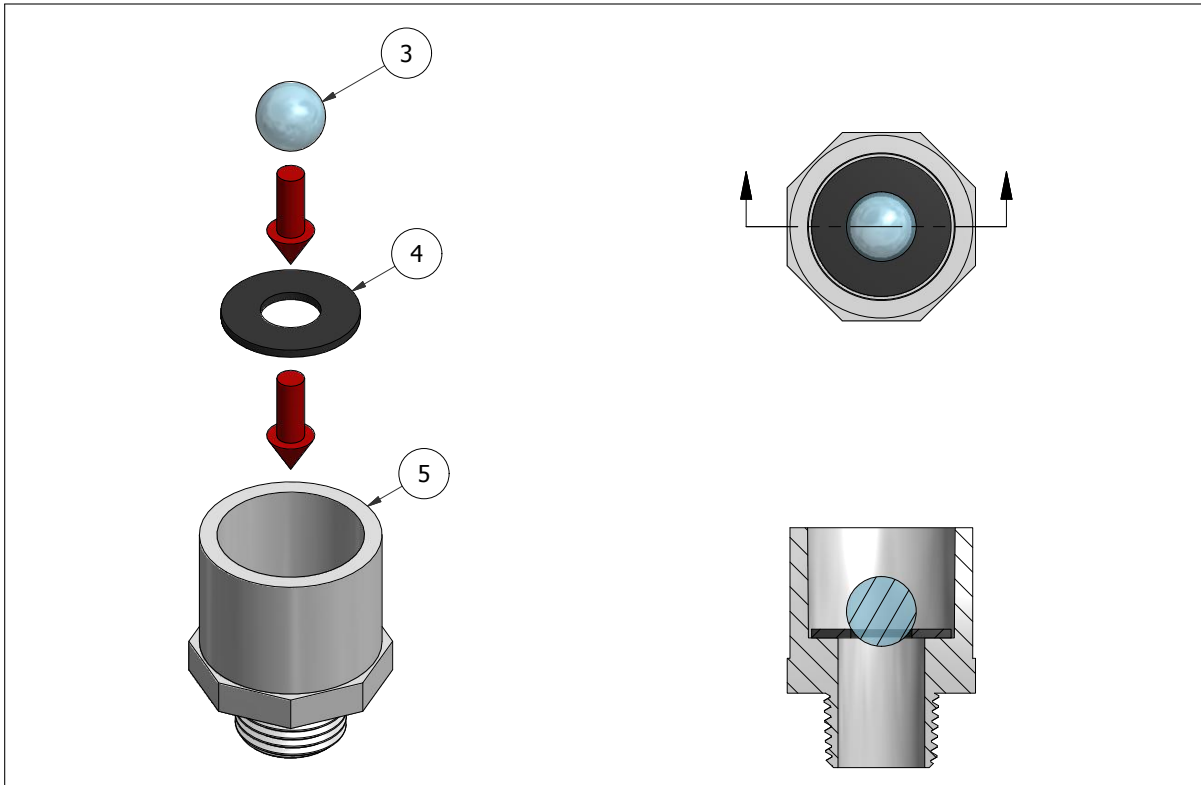

part no.	description	dimensions	material	qty
03	standard marble	1/2" \varnothing	glass	1
04	rubber washer	7/16" ID, 1" OD, 1/16" thickness	rubber	1
05	reducer	3/4" unthreaded female to 1/2" threaded male	PVC, sch. 40	1

Step 03: Insert pipe piece into reducer and cement in place.

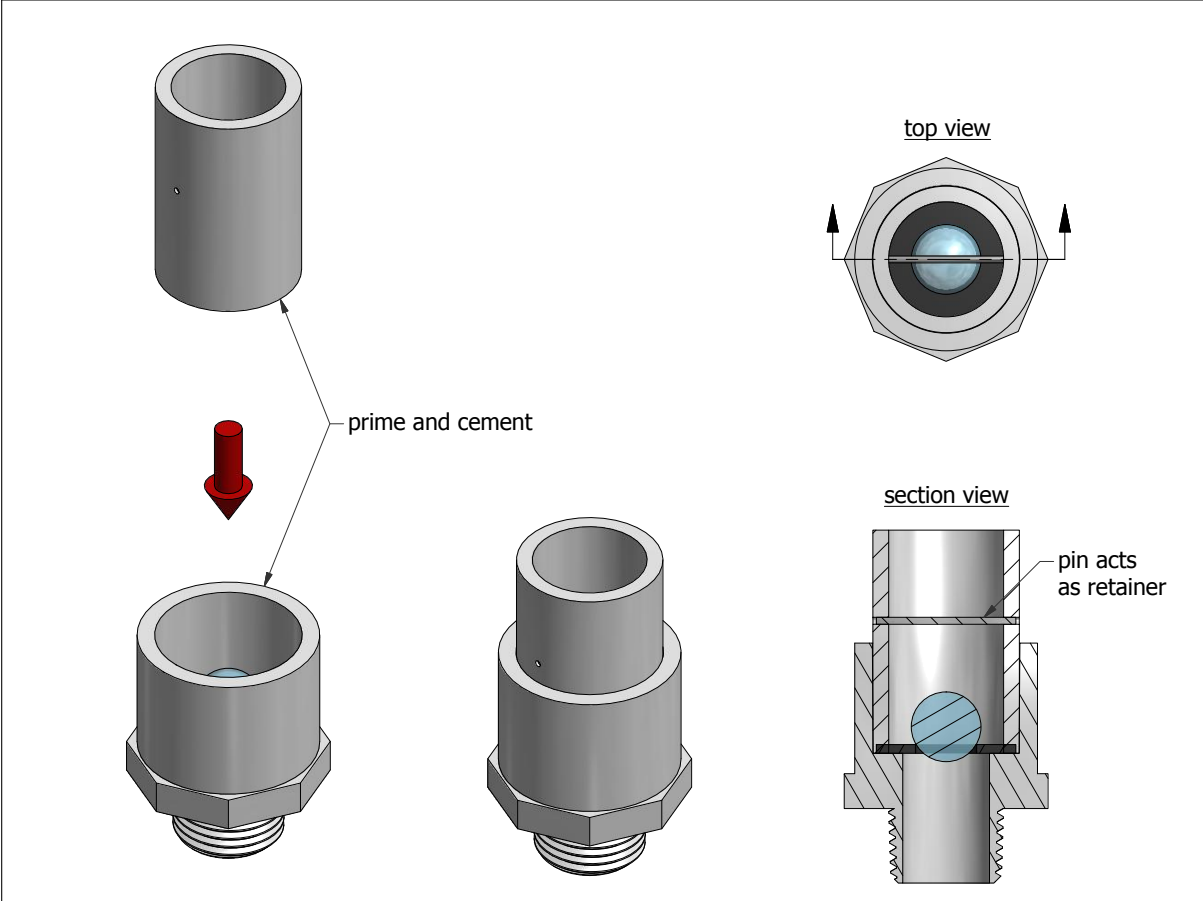

Step 04: Apply tape to indicate direction and attach 2nd reducer and cement in place.
Repeat steps 1 through 4 to complete two check valves.

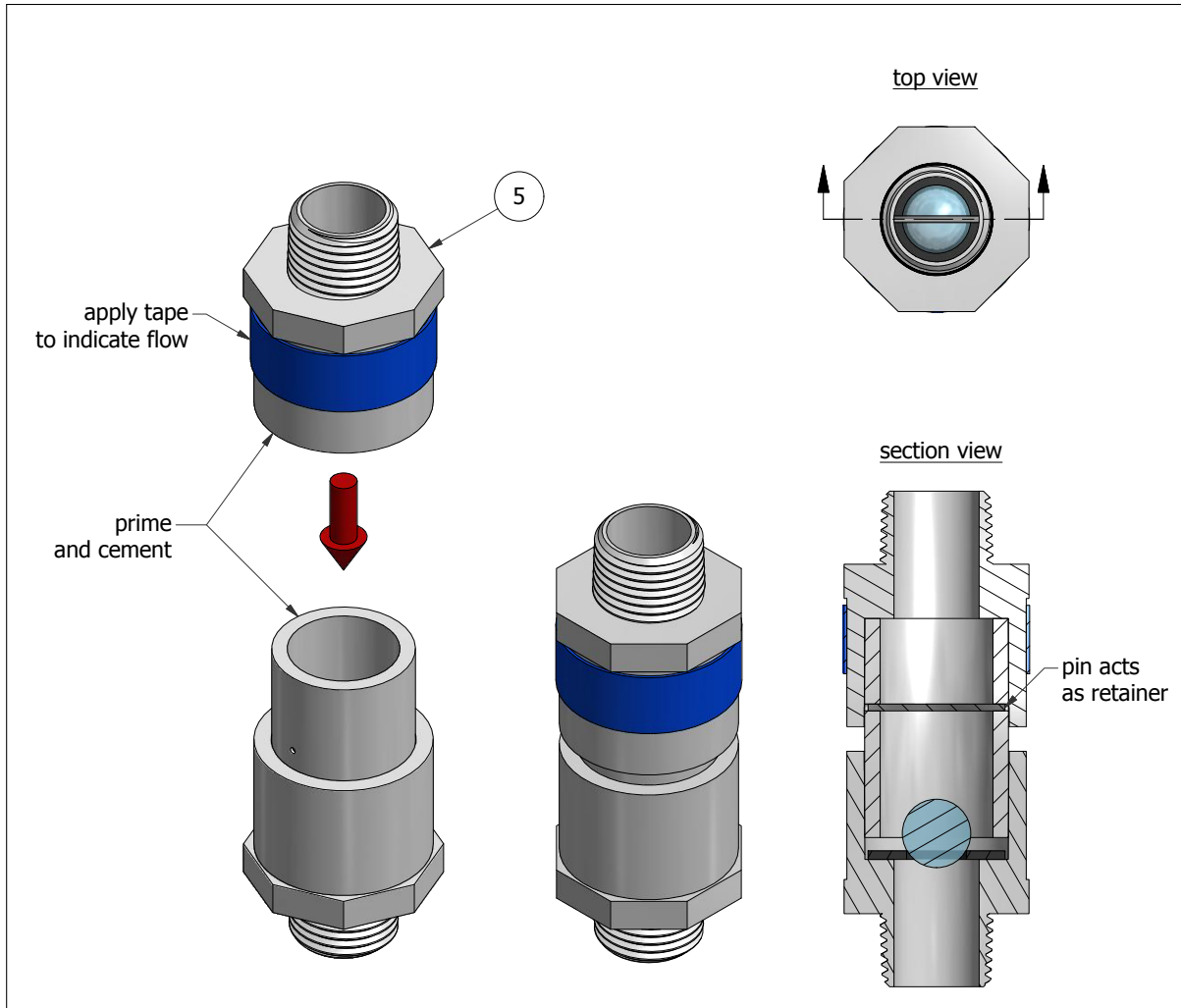

part no.	description	dimensions	material	qty
05	reducer	3/4" unthreaded female to 1/2" threaded male	PVC, sch. 40	1

Step 05: Cut two recesses in exterior surface of 1/2" pipe piece.

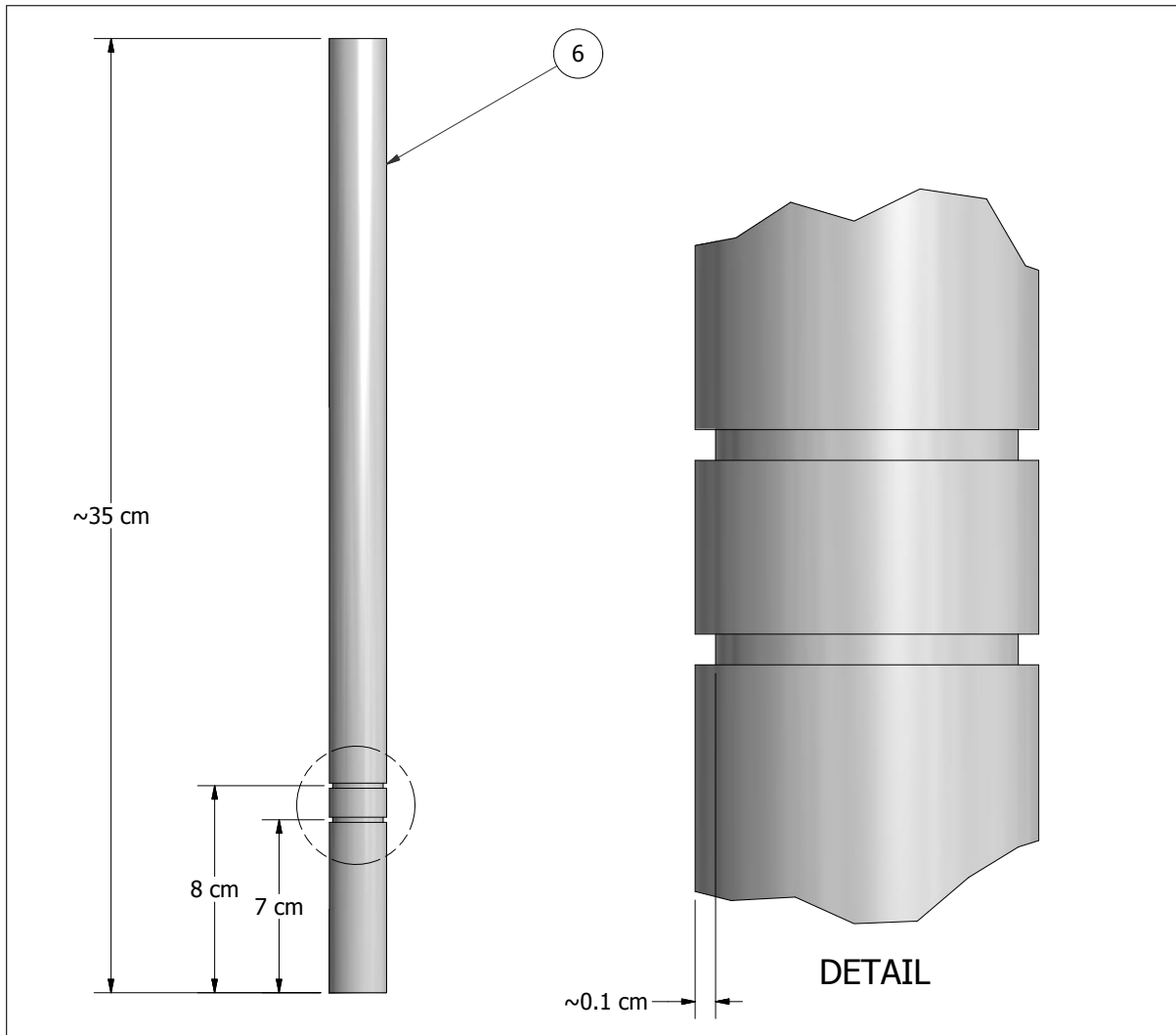

part no.	description	dimensions	material	qty
06	pipe piece	1/2" \varnothing , 35 cm long	PVC - sch. 40	1

Step 06: Slide 2 O-rings onto pipe, insert plug, attach adapter and tee.

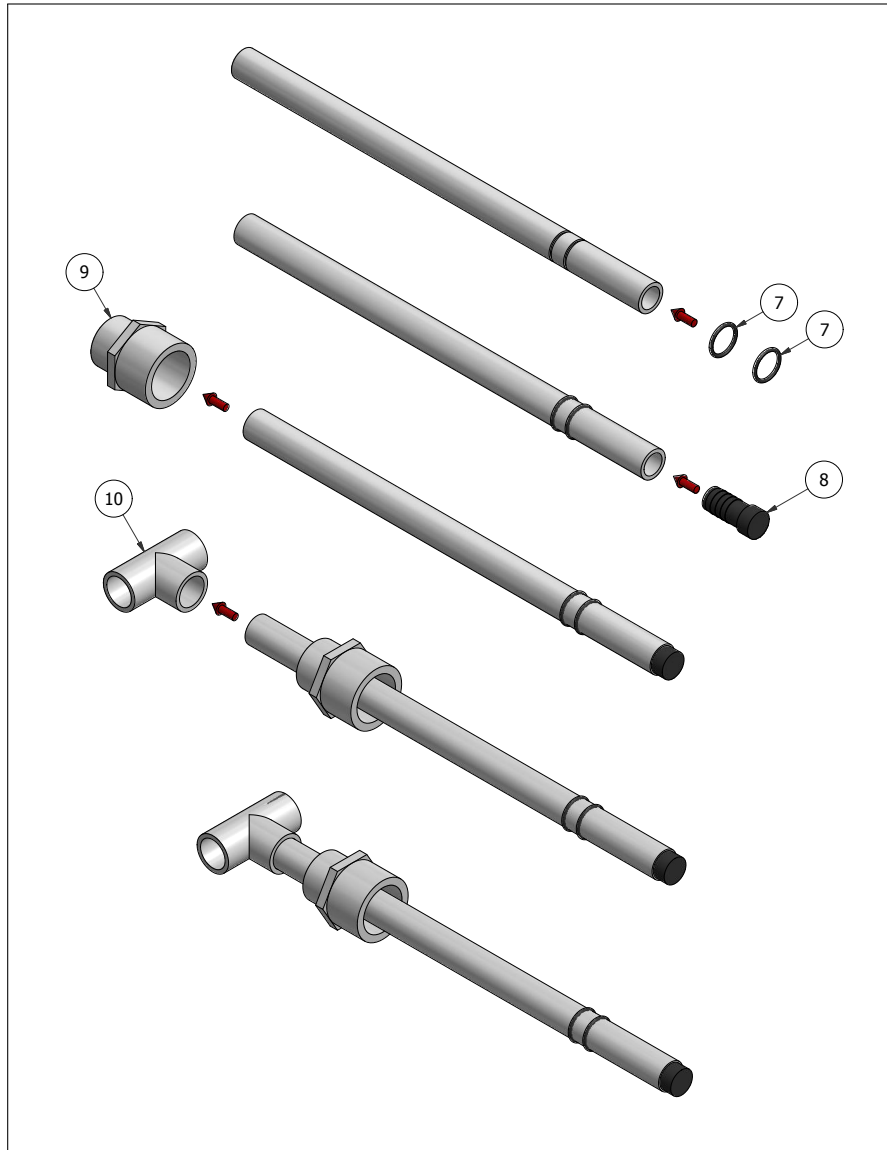

part no.	description	dimensions	material	qty
07	o-ring	#14 - 15/16" OD, 3/4" ID	PTFE	2
08	barbed plug	for ID of 1/2" sch. 40 pipe	PVC	1
09	adapter	1" unthreaded female to 3/4" threaded female	PVC - sch. 40	1
10	handle tee	1/2" all ends unthreaded	PVC - sch. 40	1

Step 07: Separate parts of filter bowl.

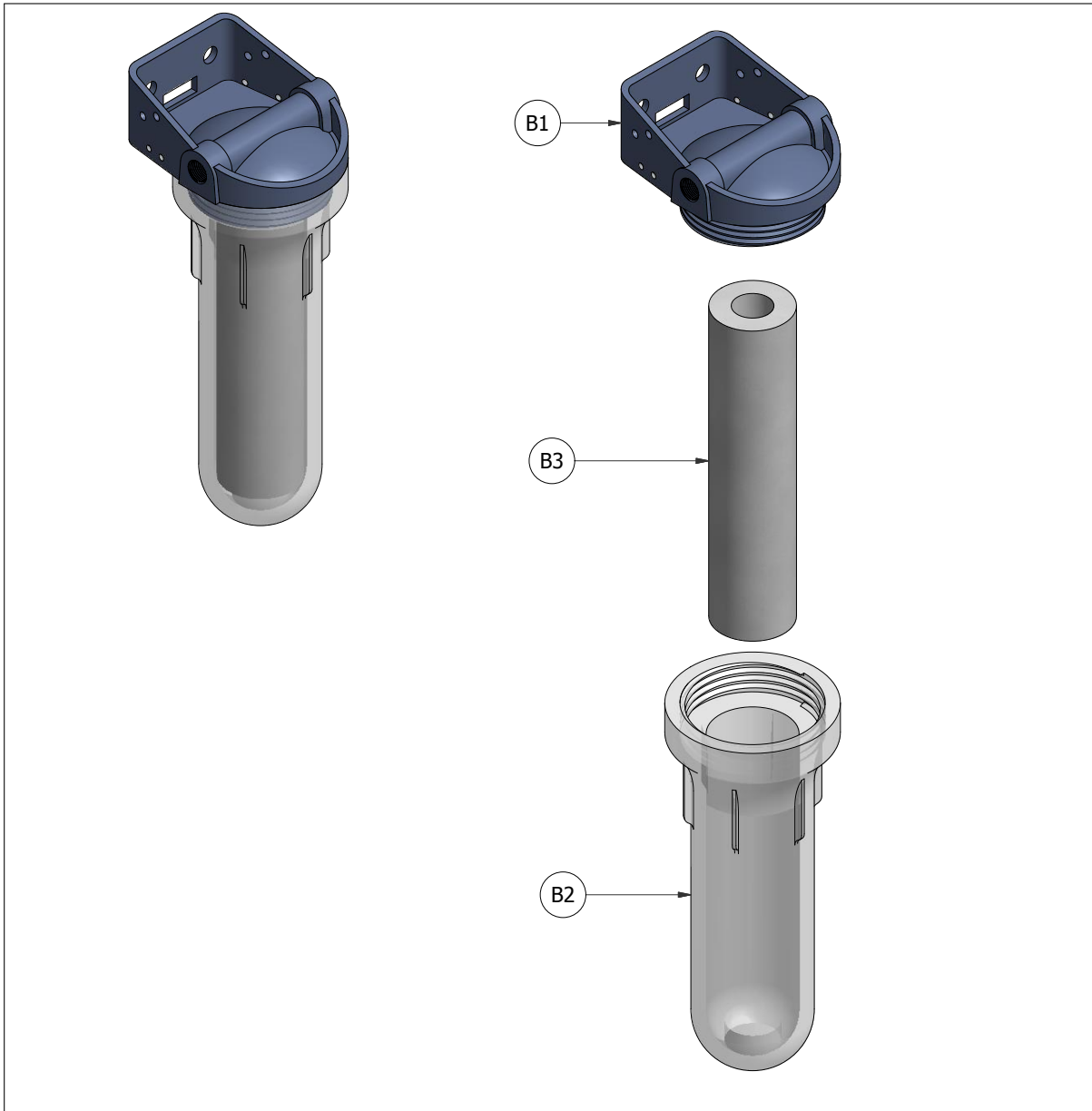

part no.	description	dimensions	material	qty
B1	filter bowl head	manufactured	plastic	1
B2	filter bowl	premanufactured length	plastic	1
B3	filter cartridge	10" standard nominal length	-	1

Step 08: Insert two elbows into a tee and cement in place.

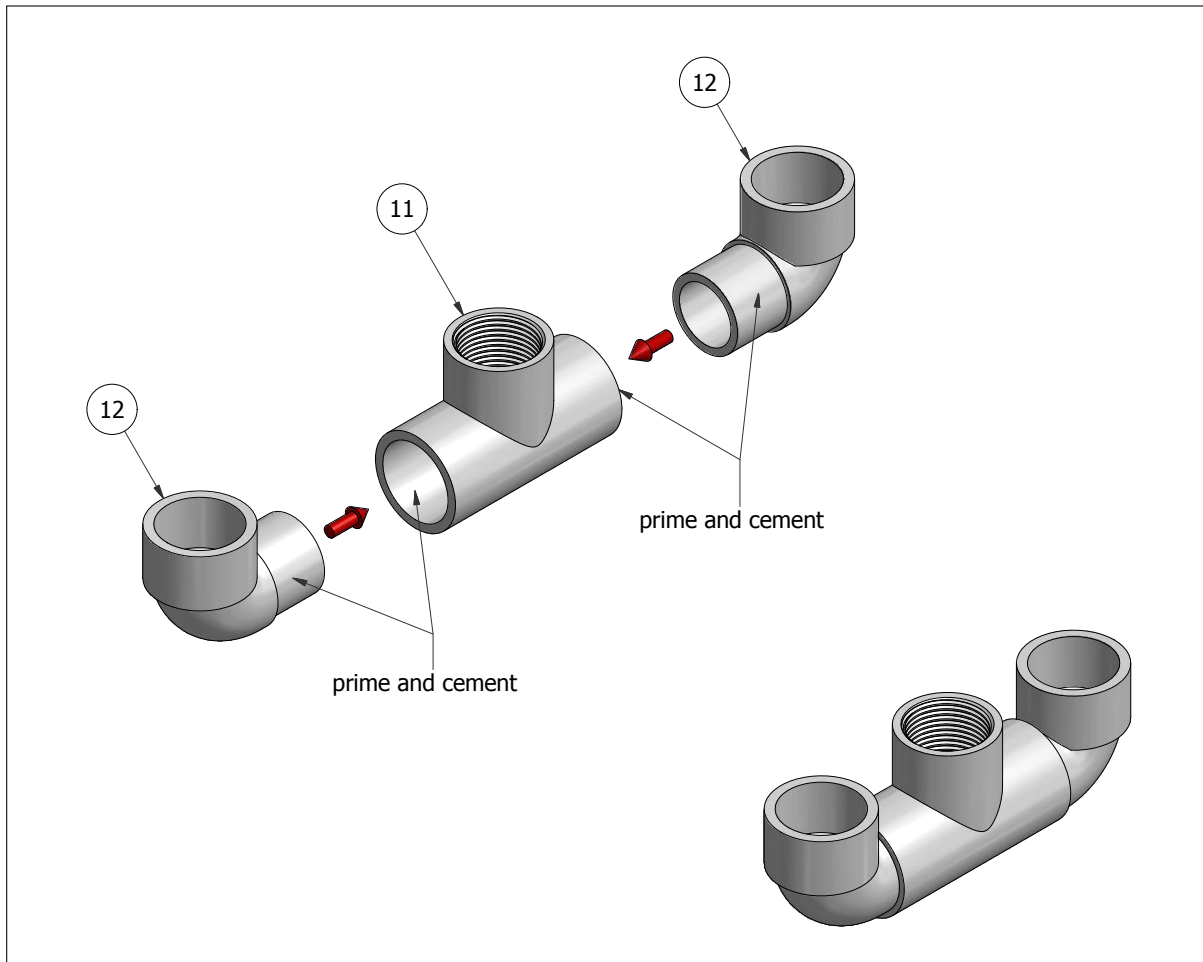

part no.	description	dimensions	material	qty
11	tee, female	1", 1 end threaded, 2 ends unthreaded	PVC - sch. 40	1
12	elbow, male to female	1", both ends unthreaded	PVC - sch. 40	2

Step 09: Cement in place a socket bushing in one elbow and a threaded in the other.

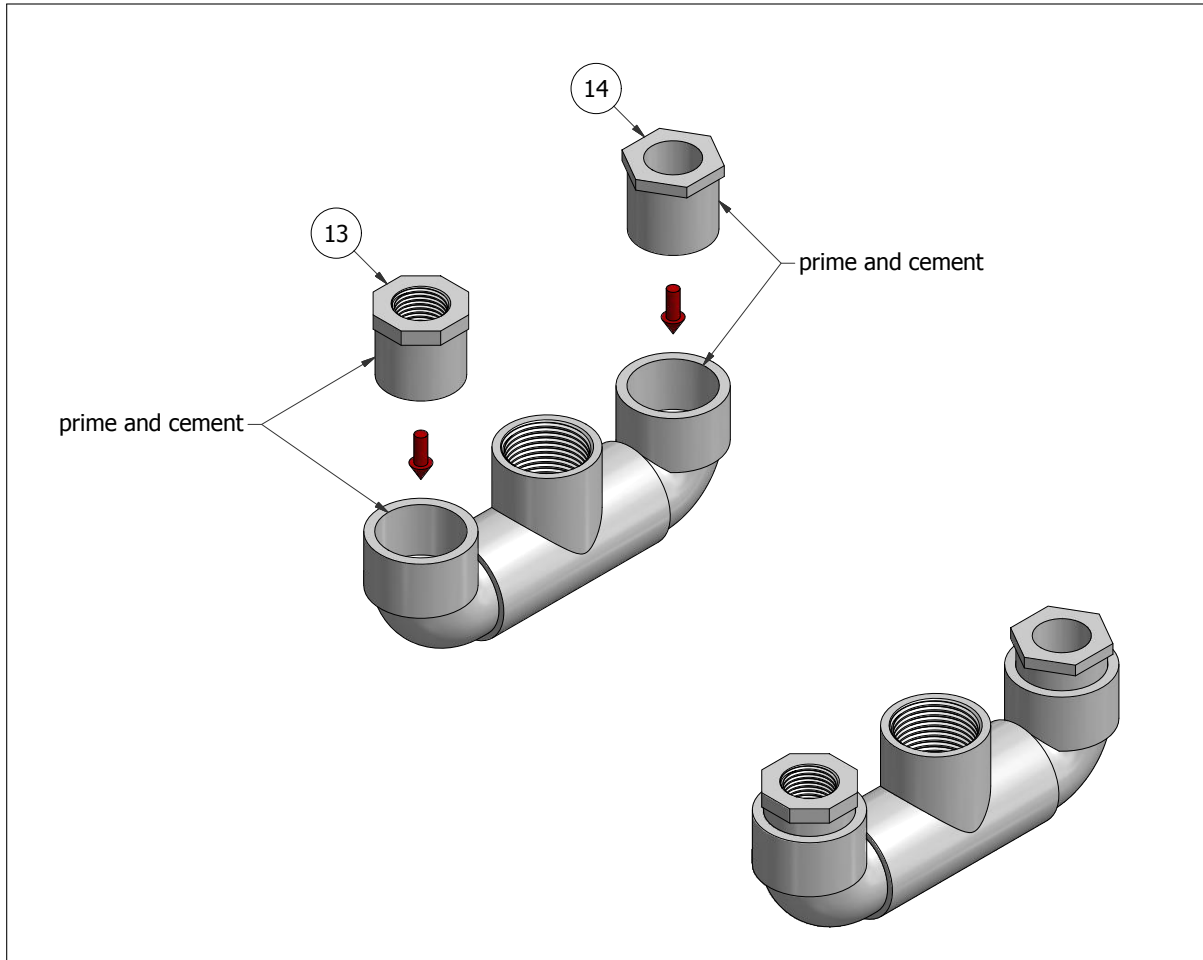

part no.	description	dimensions	material	qty
13	bushing	1" unthreaded male to 1/2" threaded female	PVC - sch. 40	1
14	bushing	1" unthreaded male to 1/2" unthreaded female	PVC - sch. 40	1

Step 10: Insert a pipe piece into the socket bushing and cement in place.

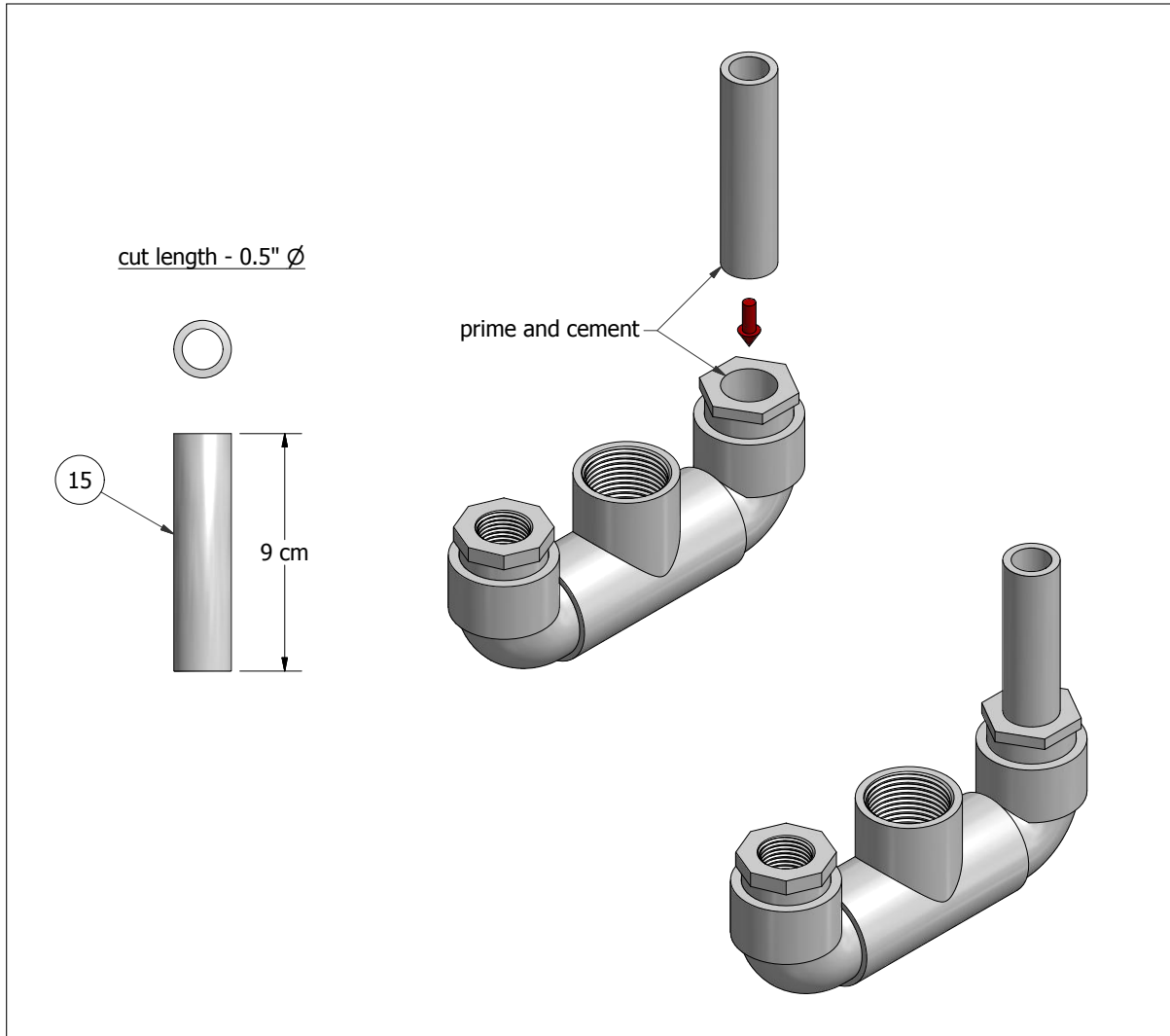

part no.	description	dimensions	material	qty
15	pipe piece	1/2", ~ 9 cm long	PVC - sch. 40	1

Step 11: Insert one of the check valves into the threaded bushing.

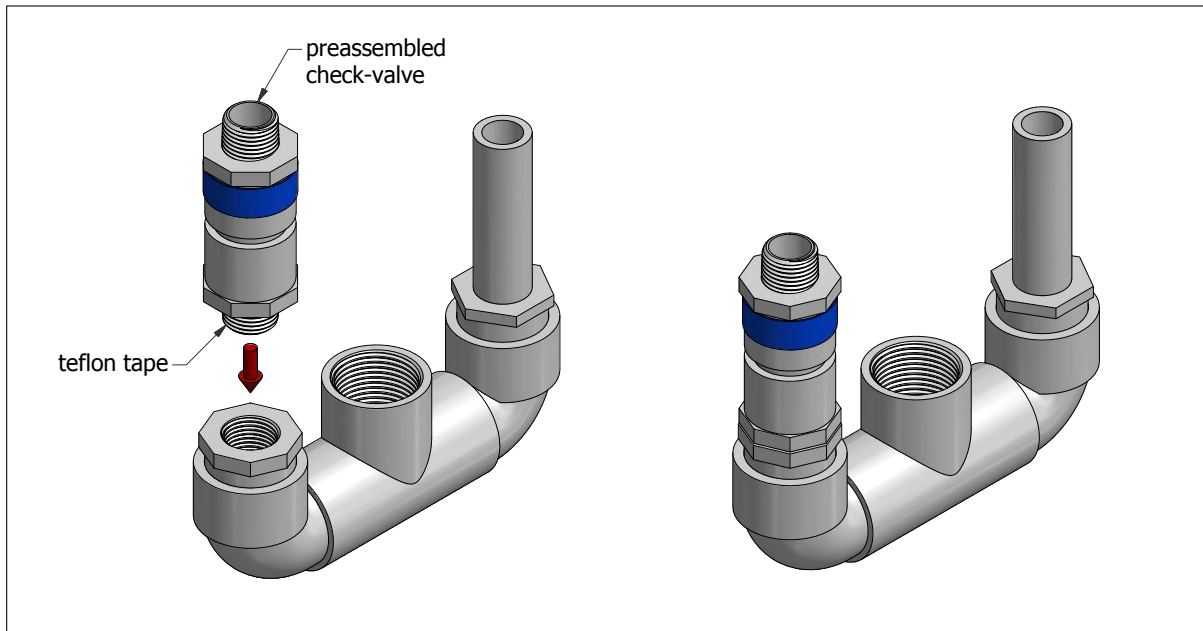

Step 12: Attach filter bowl head to previous assembly with hose clamps.

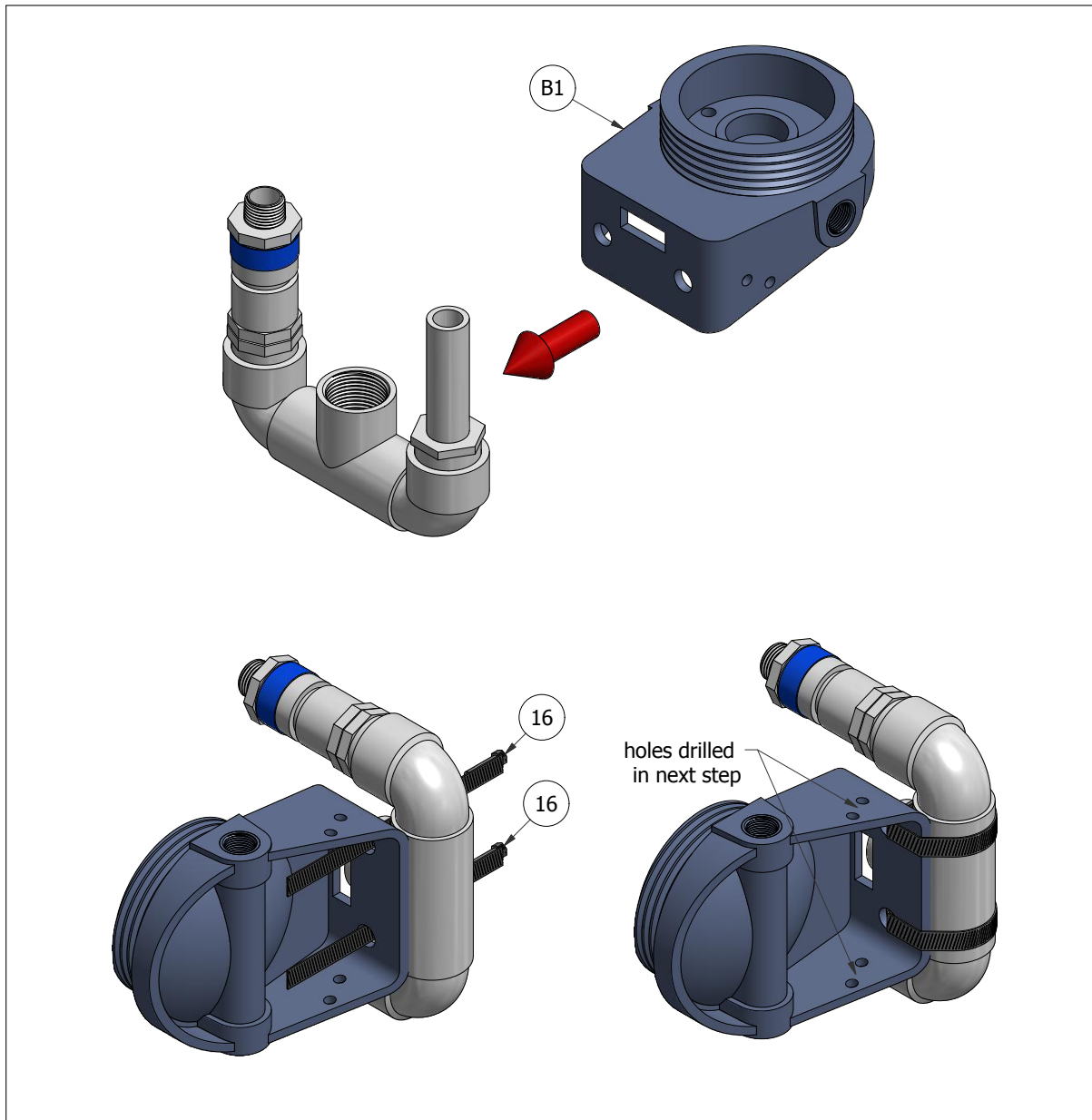

part no.	description	dimensions	material	qty
B1	filter bowl head	manufactured	plastic	1
16	hose clamp	for ~ 1 1/2" \varnothing	non-rusting metal	2

Step 13: Drill matching holes in filter bowl head and through metal strips.

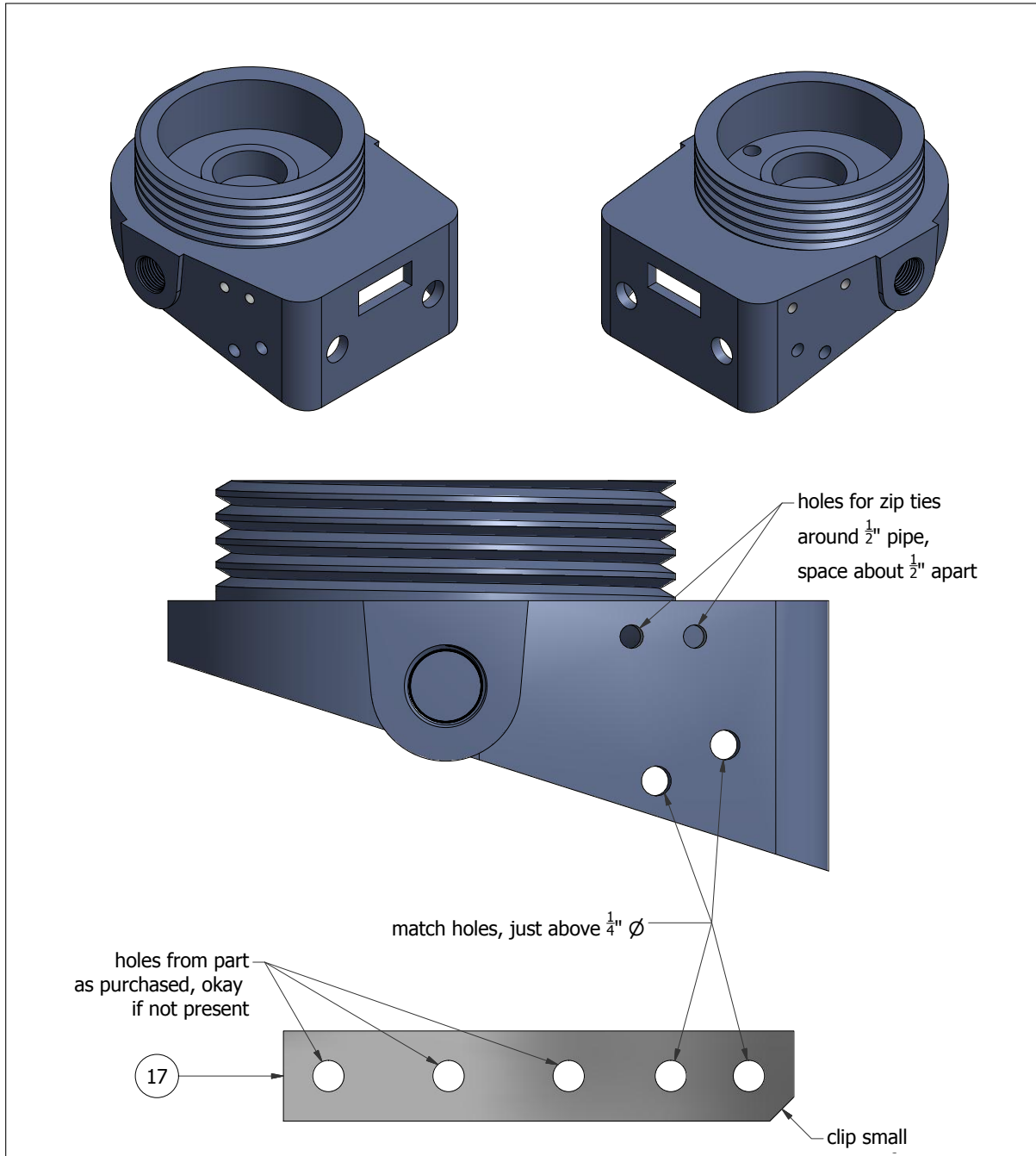

part no.	description	dimensions	material	qty
17	metal bar/strip	$\frac{3}{4}$ " wide, ~ 4.25" long	non-rusting metal	2

Step 14: Attach metal strips to filter bowl head.

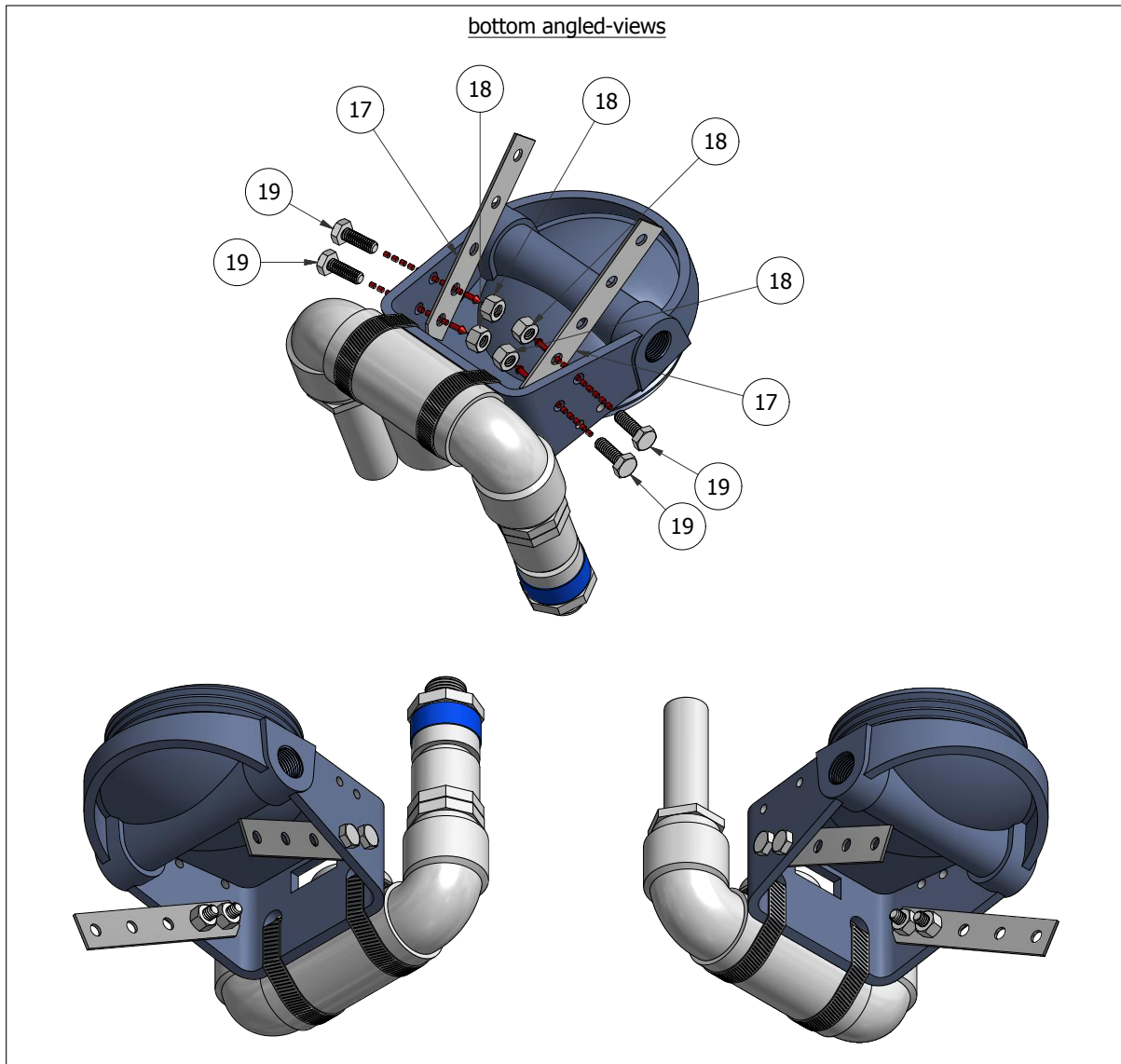

part no.	description	dimensions	material	qty
17	metal bar	3/4" wide, ~ 4.25" long	non-rusting metal	2
18	nut	1/4" – 20	non-rusting metal	4
19	bolt	1/4" – 20, 3/4" long	non-rusting metal	4

Step 15: Insert barbed fittings into both filter bowl head openings.

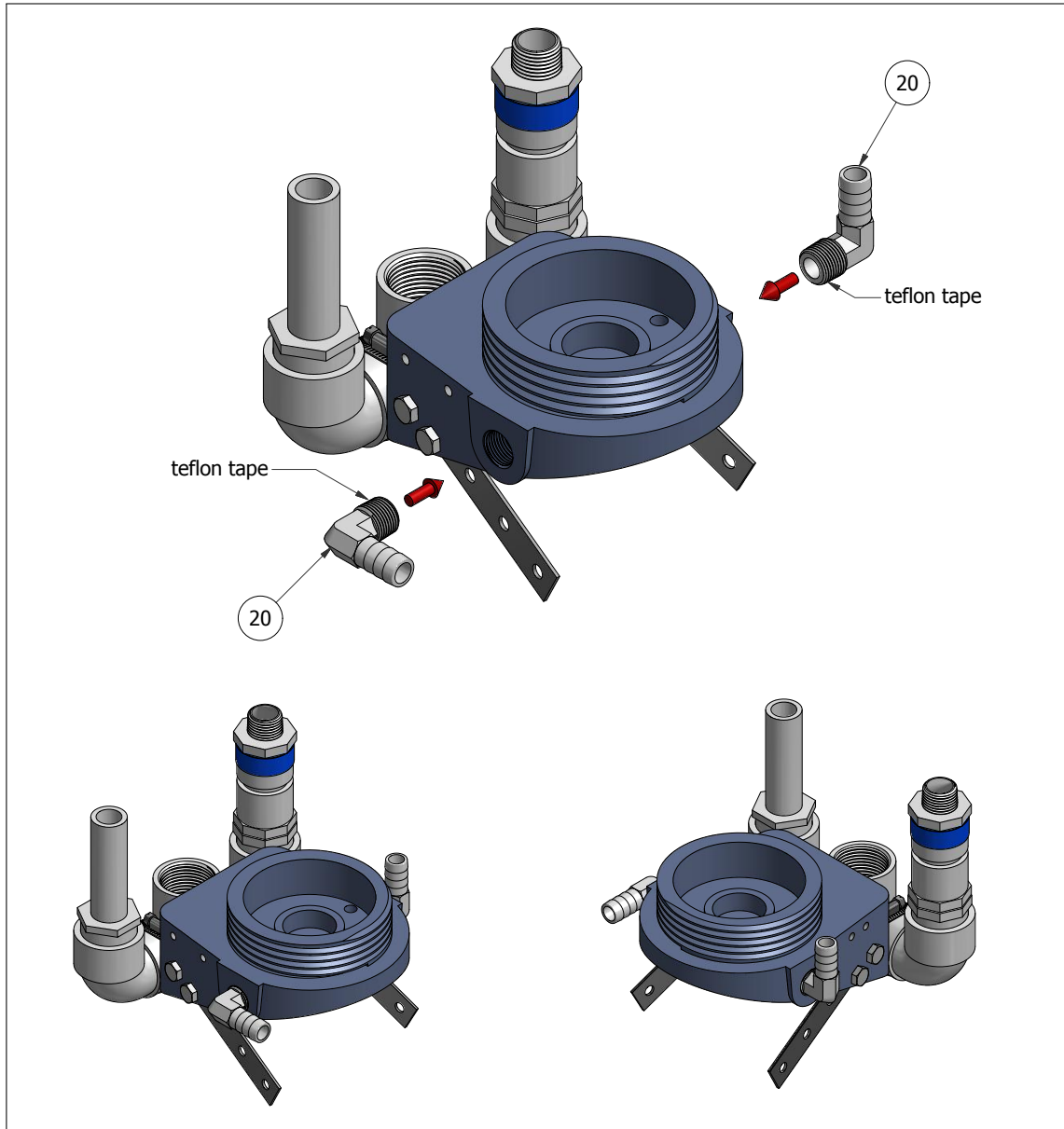

part no.	description	dimensions	material	qty
20	barbed elbow	match male threading to filter head, barbed outlet for tube of 1/2" ID	PVC or nylon	2

Step 16: Insert male thread, female socket elbow into full male thread elbow.

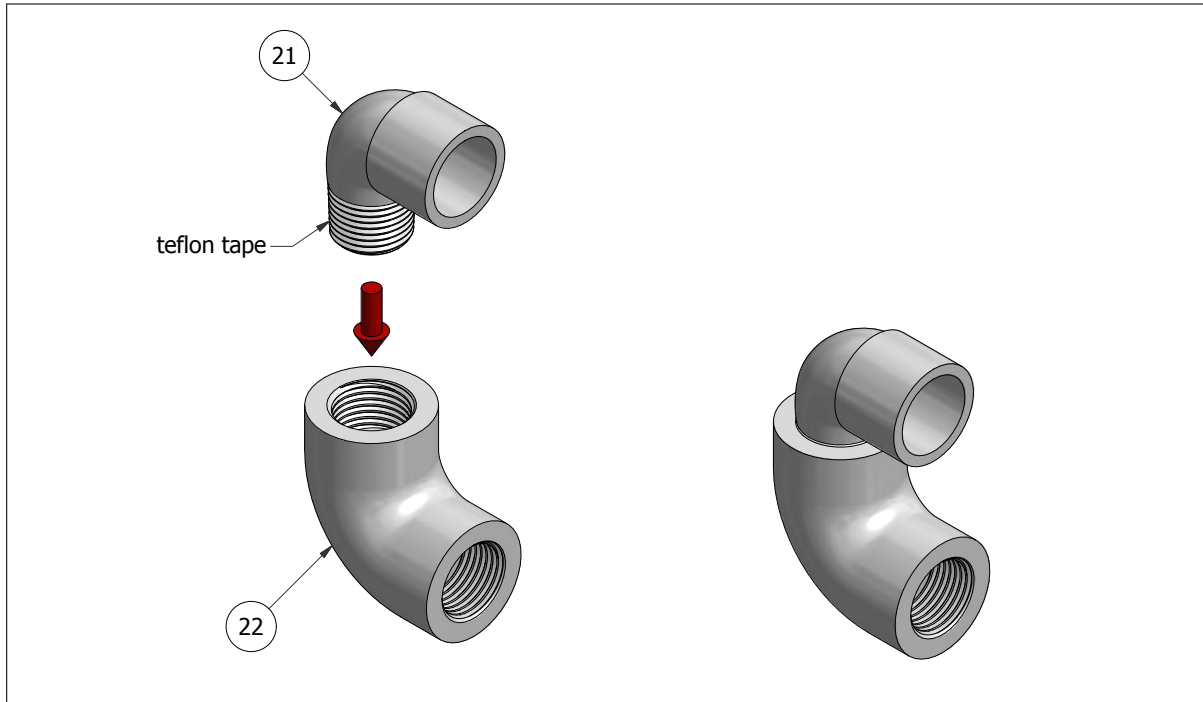

part no.	description	dimensions	material	qty
21	male-female elbow	1/2", threaded male to unthreaded female	PVC, sch. 40	1
22	female-female elbow	1/2", female-female threaded	PVC sch. 40	1

Step 17: Insert other check valve into elbow.

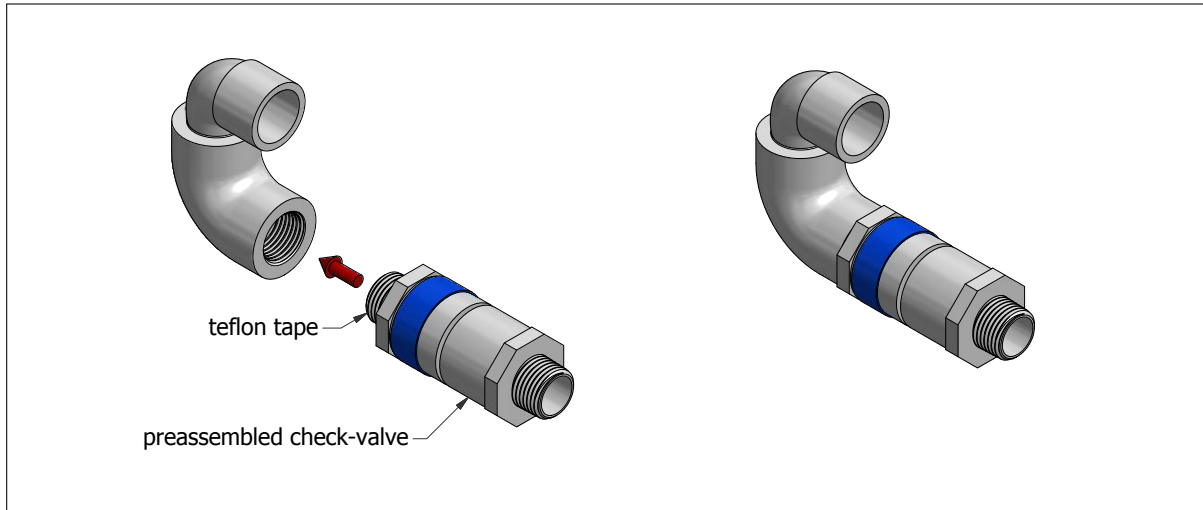

Step 18: Attach elbow to other end of check valve.

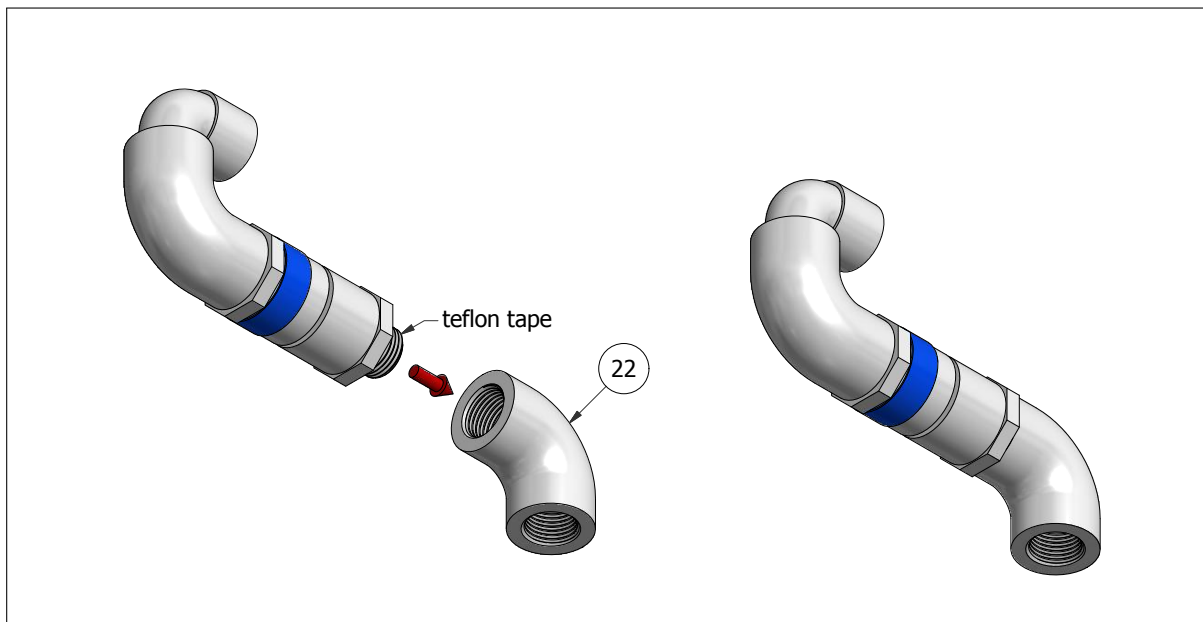

part no.	description	dimensions	material	qty
22	female-female elbow	1/2", female-female threaded	PVC sch. 40	1

Step 19: Insert barbed fitting into other end of elbow.

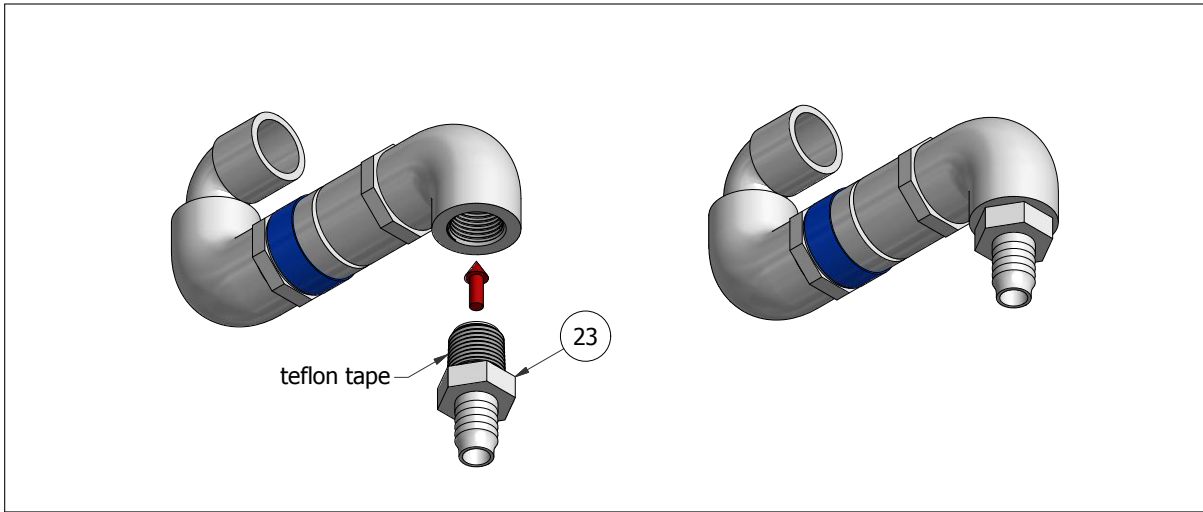

part no.	description	dimensions	material	qty
23	barbed fitting	1/2" male threaded to barbed outlet for tube of 1/2" ID	nylon	1

Step 20: Attach elbow of previous assembly to pipe piece.

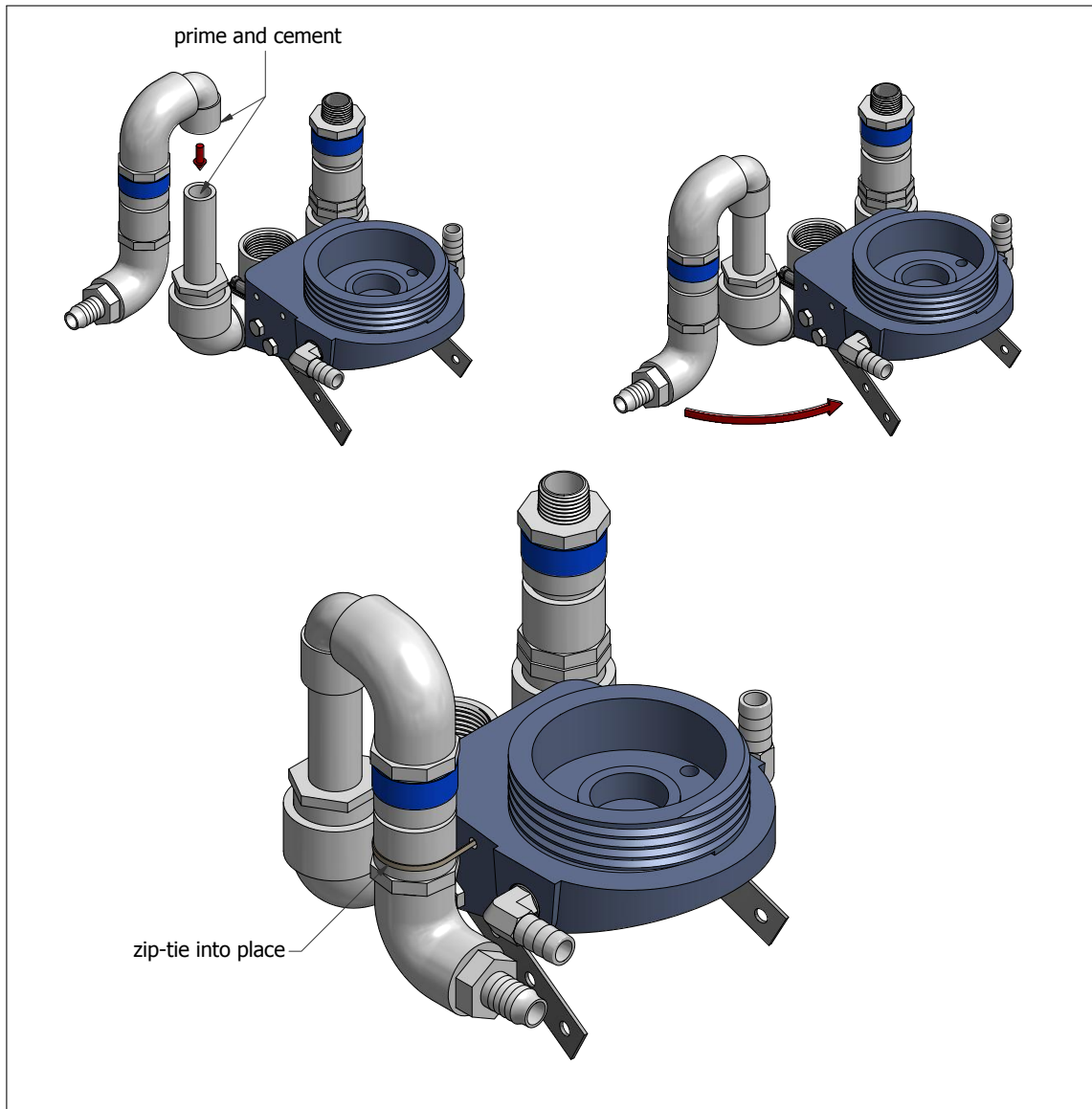

part no.	description	dimensions	material	qty
-	zip tie	-	nylon	1

Step 21: Attach connection hose with hose clamps.

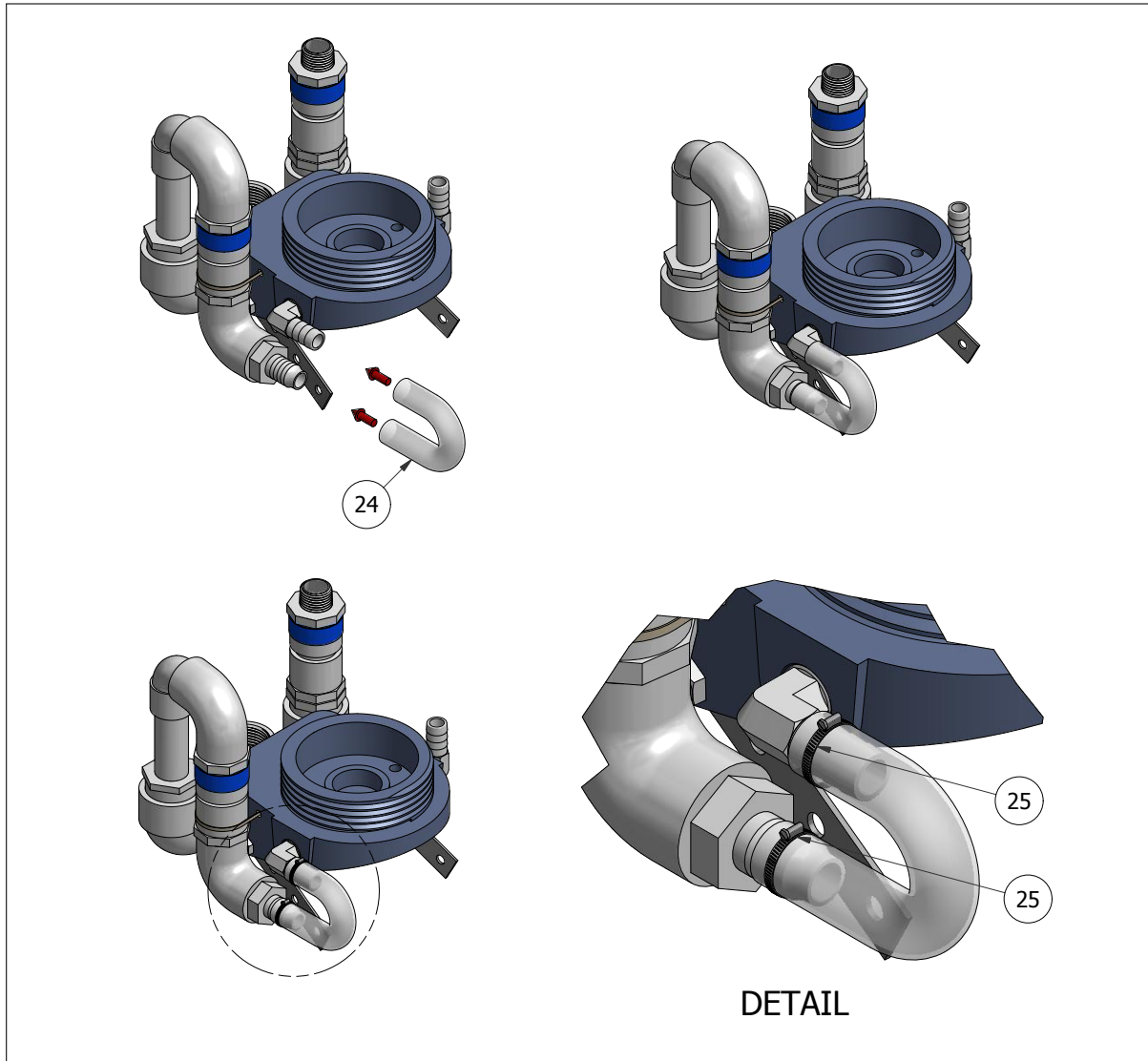

part no.	description	dimensions	material	qty
24	flexible tube	1/2" ID, ~ 5" long	polyvinyl	1
25	hose clamp	for ~ 3/4" \varnothing	non-rusting metal	2

Step 22: Attach full male thread elbow and male thread, female socket elbow.

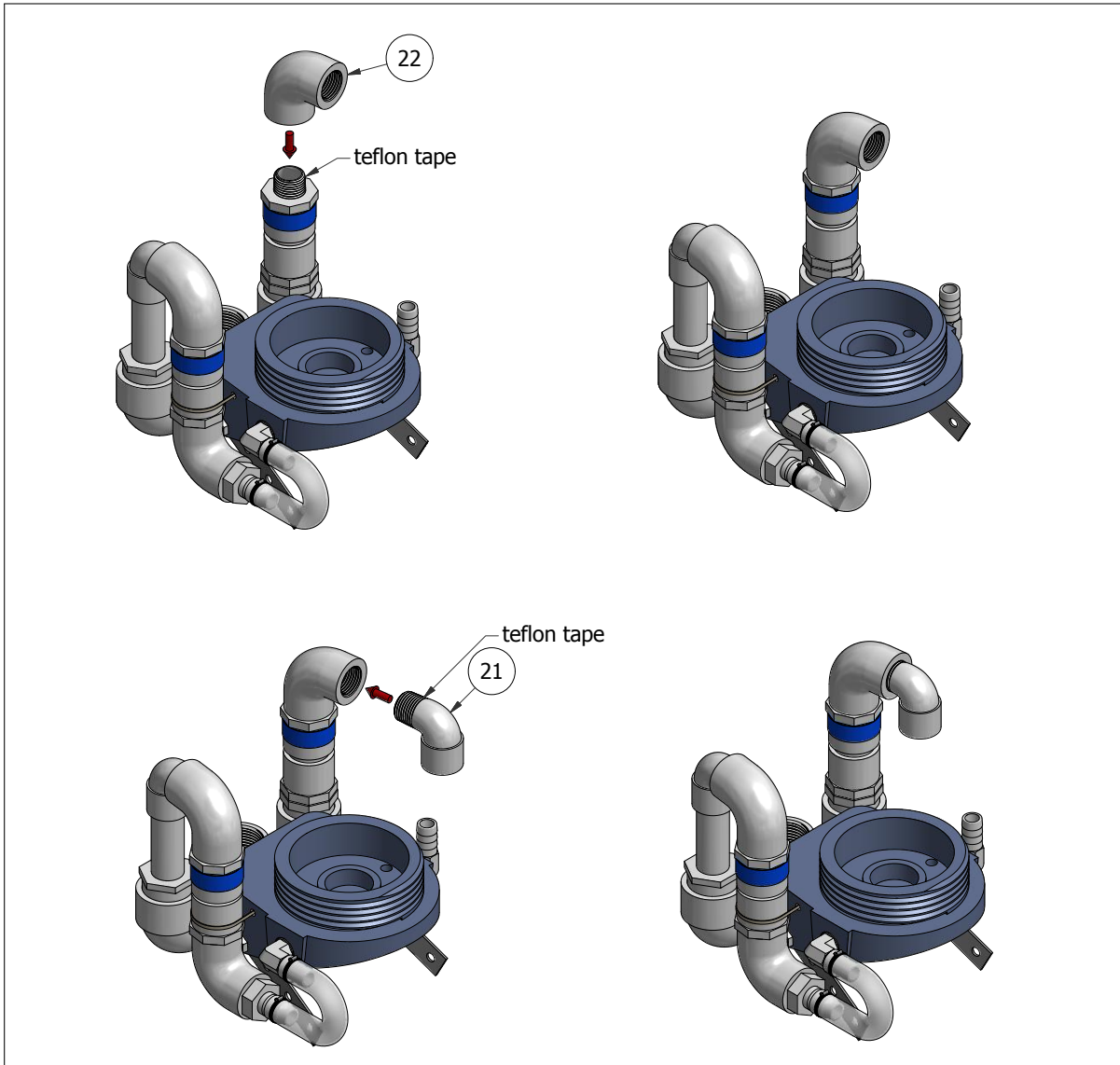

part no.	description	dimensions	material	qty
21	male-female elbow	1/2", threaded male to unthreaded female	PVC, sch. 40	1
22	female-female elbow	1/2", female-female threaded	PVC, sch. 40	1

Step 23: Insert pipe piece into elbow and secure with zip tie.

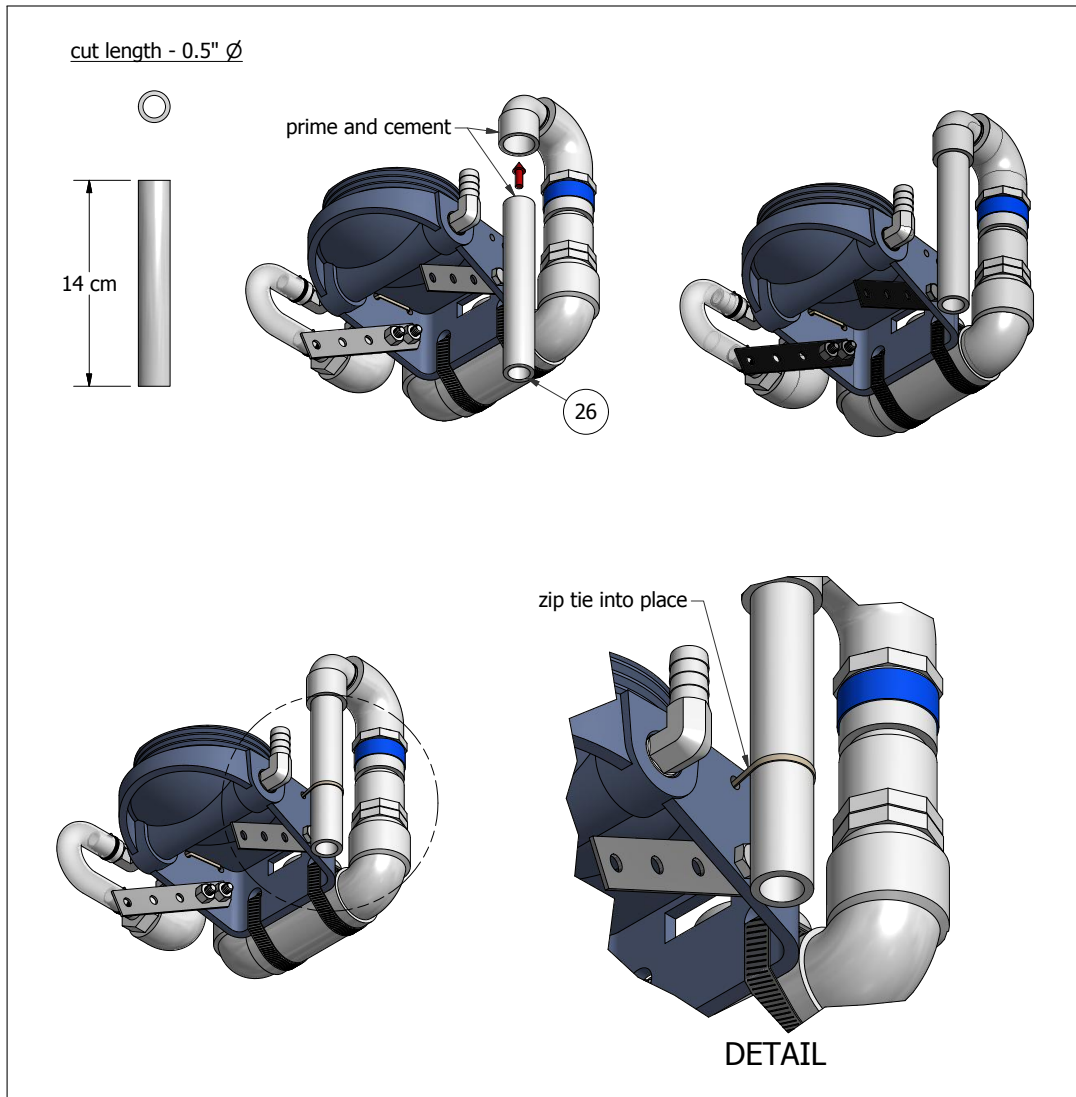

part no.	description	dimensions	material	qty
26	pipe piece	1/2", 14cm long	PVC - sch. 40	1

Step 24: Insert nipple into tee.

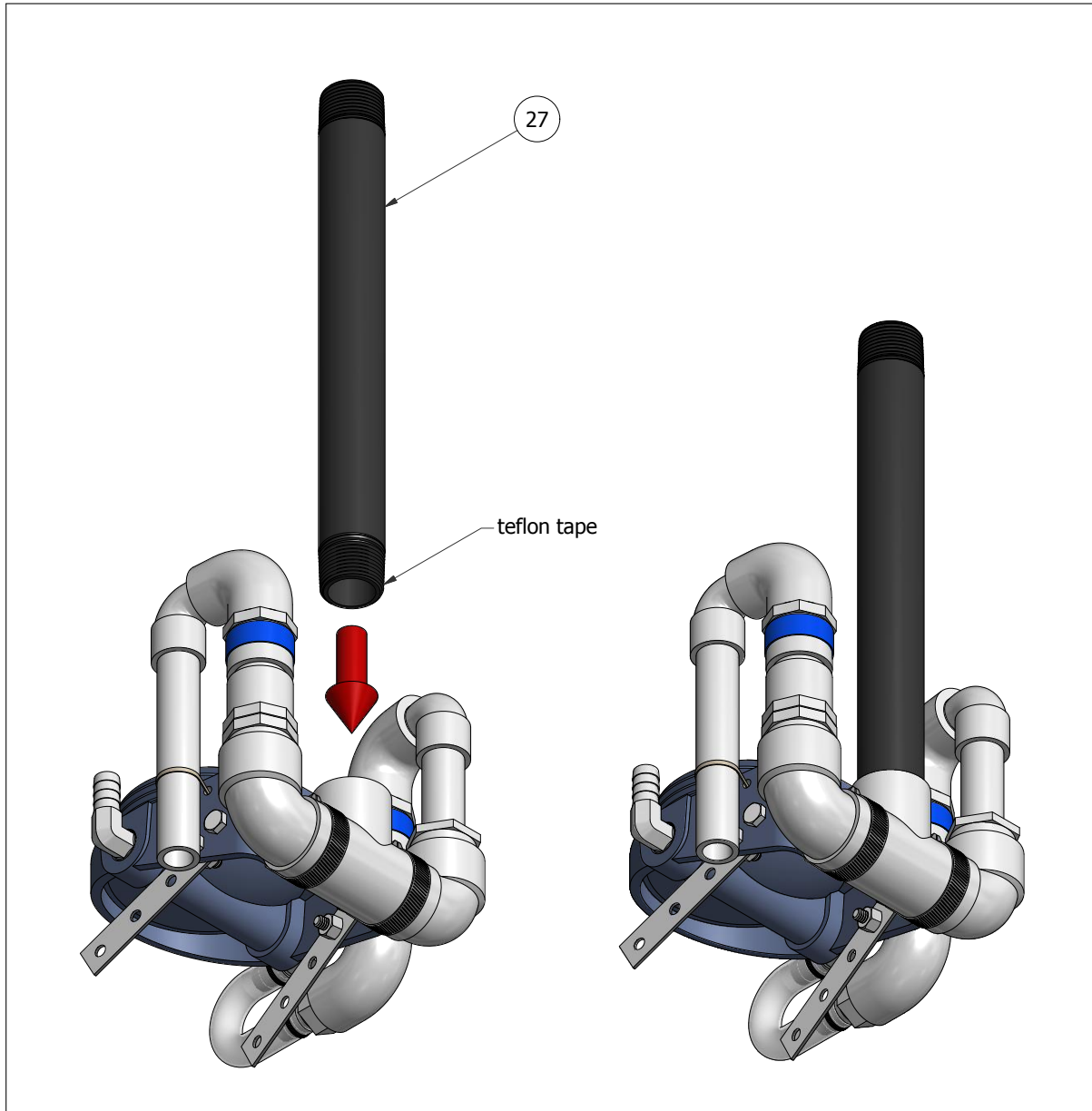

part no.	description	dimensions	material	qty
27	threaded nipple	1"Ø, 14cm long	PVC - sch. 80	1

Step 25: Attach mounting clips.

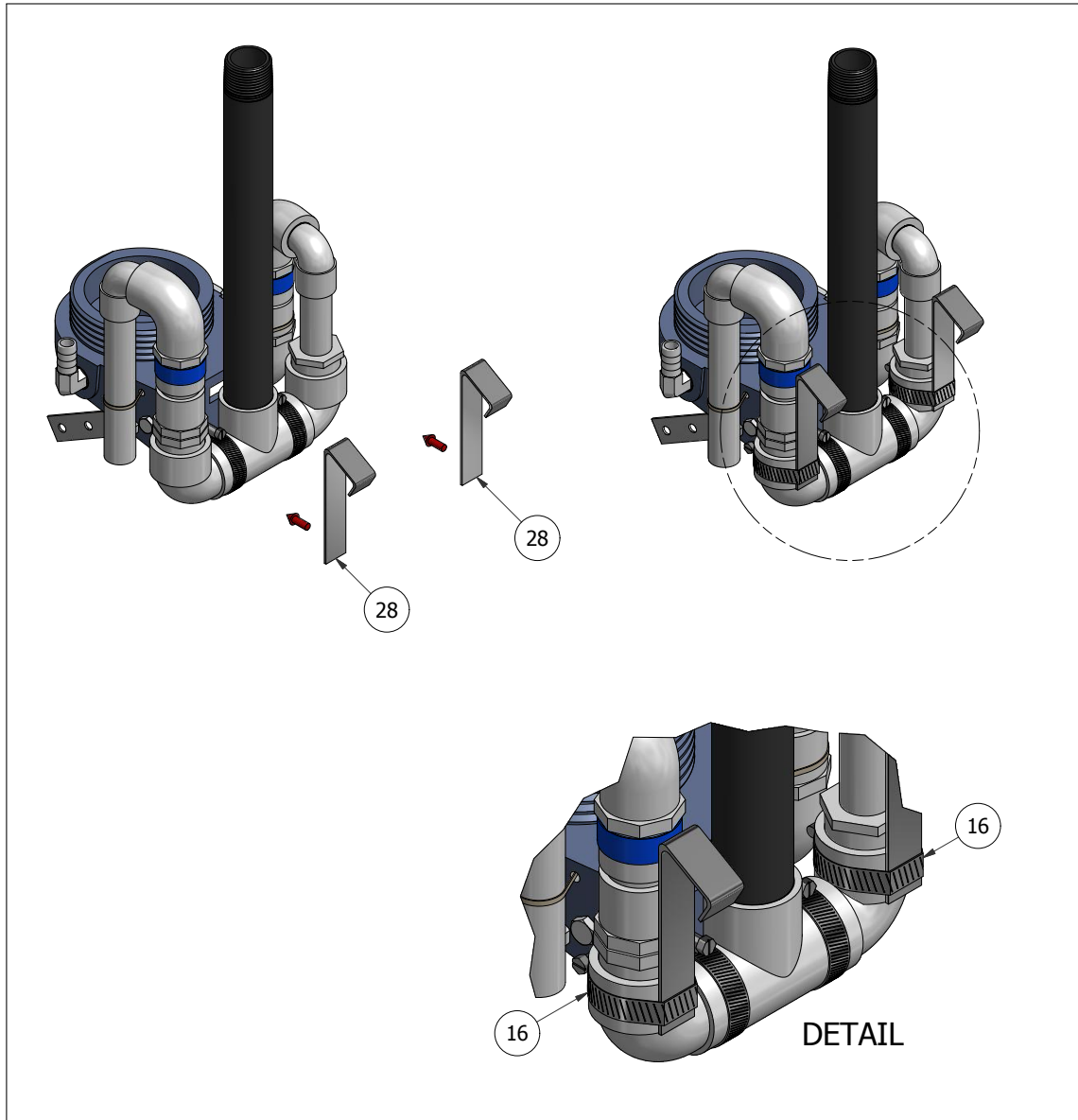

part no.	description	dimensions	material	qty
28	bent clip	bend to latch onto anticipated container, unbent length ~ 4.25"	non-rusting metal	2
16	hose clamp	for ~ 1 1/2" \varnothing	non-rusting metal	2

Step 26: Attach filter cartridge and filter bowl.

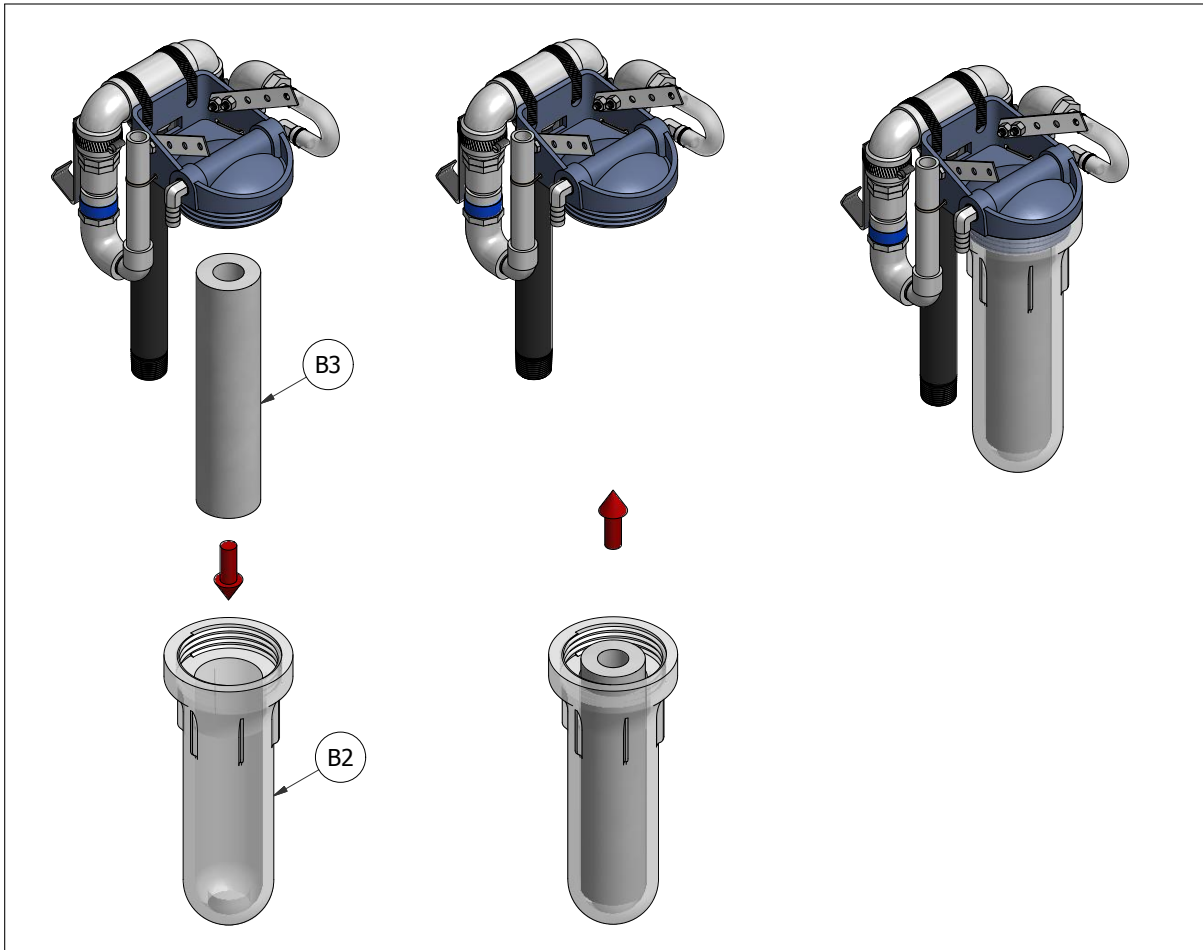

part no.	description	dimensions	material	qty
B2	filter bowl	premanufactured length	plastic	1
B3	filter cartridge	10" standard nominal length	-	1

Step 27: Attach inlet tube and secure with hose clamp.

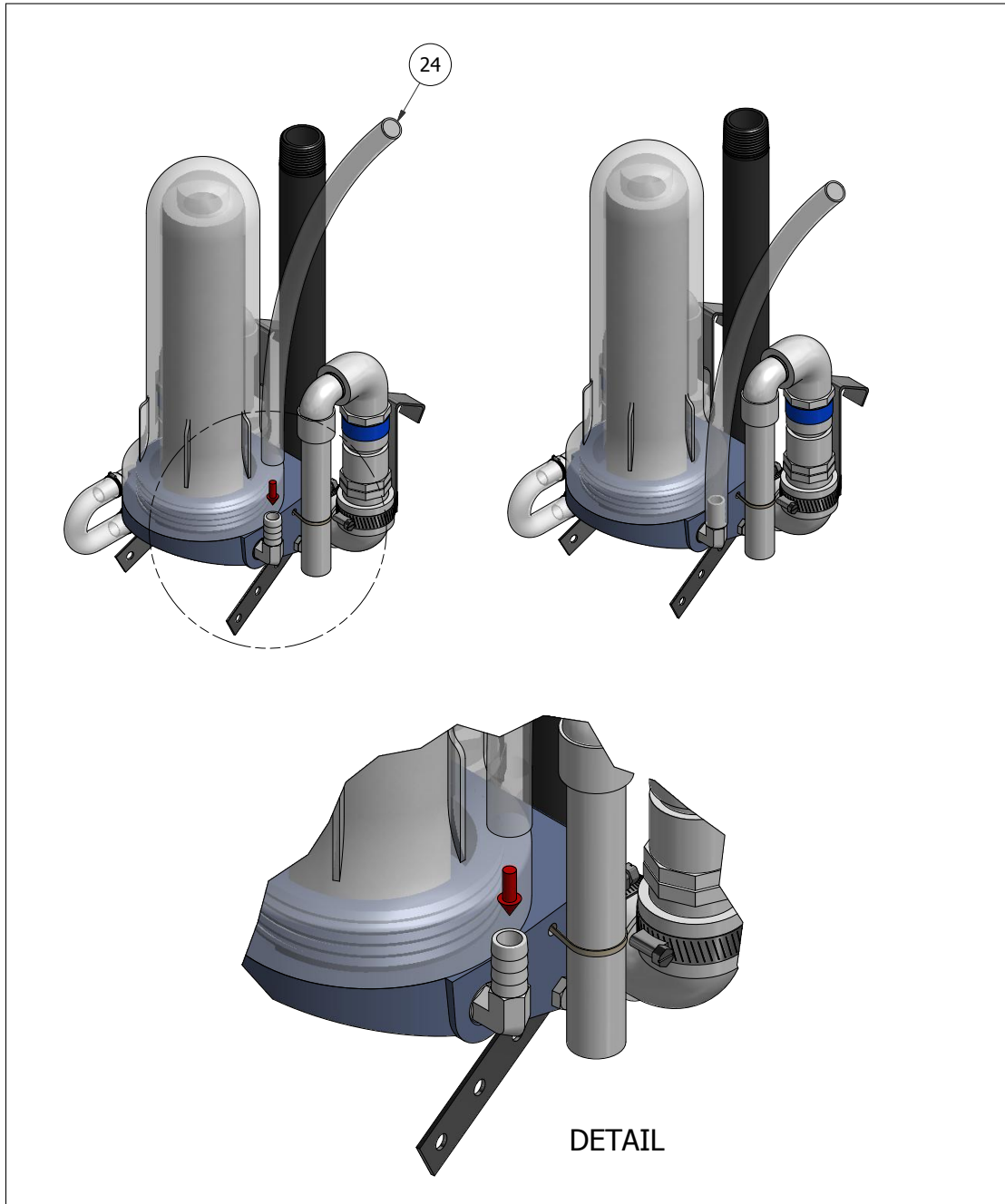

part no.	description	dimensions	material	qty
24	flexible tube	cut to desired length ~ 14" shown	polyvinyl	1

Step 28: Insert previous assembly.

